



FITTING INSTRUCTIONS

Part Number: **3540360T**
Product: TWIN COMPRESSOR, ON BOARD AIR
Description:
Suited to: FORD RANGER MY22
vehicle/s:
Options: **171503 MANIFOLD KIT**
Required for Air Locker Solenoids
Recommended for all air accessories.

3501051 COUPLING *Required for DRAWERS*

Please place these instructions in vehicle glovebox when complete.

WARNING

ALSO, NOTE THE FOLLOWING:

- ◆ This product must be installed exactly as per these instructions using only the hardware supplied.
- ◆ Do not use this product for any vehicle make or model, other than those specified by ARB.
- ◆ Do not remove labels from this product.
- ◆ This product or its fixing must not be modified in any way.
- ◆ The installation of this product may require the use of specialized tools and/or techniques.
- ◆ These instructions are correct as at the publication date. ARB Corporation Ltd. cannot be held responsible for the impact of any changes subsequently made by the vehicle manufacturer.
- ◆ During installation, it is the duty of the installer to check correct operation/clearances of all components.
- ◆ Work safely at all times.
- ◆ Unless otherwise instructed, tighten fasteners to specified torque.
- ◆ For heavy duty cycle operation, manifold required.

ARB 4x4 ACCESSORIES

Corporate Head Office

42-44 Garden St
Kilsyth, Victoria
AUSTRALIA 3137

Tel: +61 (3) 9761 6622
Fax: +61 (3) 9761 6807

Australian enquiries
North & South American enquiries
Other international enquiries

sales@arb.com.au
sales@arbusa.com
exports@arb.com.au

www.arb.com.au

IMPORTANT INFORMATION. GENERAL CARE AND MAINTENANCE



By choosing an ARB accessory, you have bought a product that is one of the most sought after 4WD products in the world. Your TWIN COMPRESSOR MOUNT is a properly engineered, reliable, quality accessory that represents excellent value.

FITTING REQUIREMENTS

REQUIRED TOOLS FOR FITMENT OF PRODUCT:

BASIC TOOL KIT	TORQUE WRENCH
TORX KEYS	PISTOL DRILL
Ø30.mm STEP DRILL	LOCTITE 569
MULTI TOOL	SCRIBE
DRILL BIT SET	ALLEN KEYS

HAVE AVAILABLE THESE SAFETY ITEMS WHEN FITTING PRODUCT:

Protective eyewear 	Hearing protection 
--	--

NOTE: 'WARNING' notes in the fitting procedure relate to OHS situations, where to avoid a potentially hazardous situation it is suggested that protective safety gear be worn or a safe work procedure be employed. If these notes and warnings are not heeded, injury may result.

FASTENER TORQUE SETTINGS (unless otherwise specified):

SIZE	Torque Nm	Torque lbft
M4	3	2
M6	9	7
M8	22	16

PARTS LISTING

APPLICATION.	PART NO.	QTY.	DESCRIPTION.
SUPPORT BRACKET	3753585	1	BRACKET COMPRESSOR MOUNT
	6151881	4	SCREW PHD M8x35
	6151579	2	BOLT HXHD M8x1.25x25
COMPRESSOR	6151623	8	SCREW BHD M6X1.0x16
	4584424	10	WASHER FLAT M6x18x3
	0740202B	1	HOSE REINFORCED JIC-4 0.5M
	171403	1	FEMALE PUSH-LOCK COUPLING
	37801155	1	DRILLING TEMPLATE SUITS RANGER
	CKMTAF	1	TWIN COMPRESSOR
INNER GUARD	665003	2	RIVET POP 3/16DIA1.5DomeX1.0IN
	4584424	2	WASHER FLAT M6x18x3
WIRING	6821428	1	HARNESS COMPRESSOR FORD UTE
SWITCH MOUNTING	6821430	1	HARNESS UNIVERSAL SWITCH
	180222	1	SWITCH COMPRESSOR
	3753925	1	FLUSH MNT SWITCH BRKT
	3195590	1	COMPRESSOR SWITCH MOUNT PLATE
	6151649	4	SCREW BHD M4x16 SK BTZP480
	4584294	4	WASHER FLAT M4x9x0.8 TZP480
	6151127	4	NUT HEX NYLOC M4 BTZP480

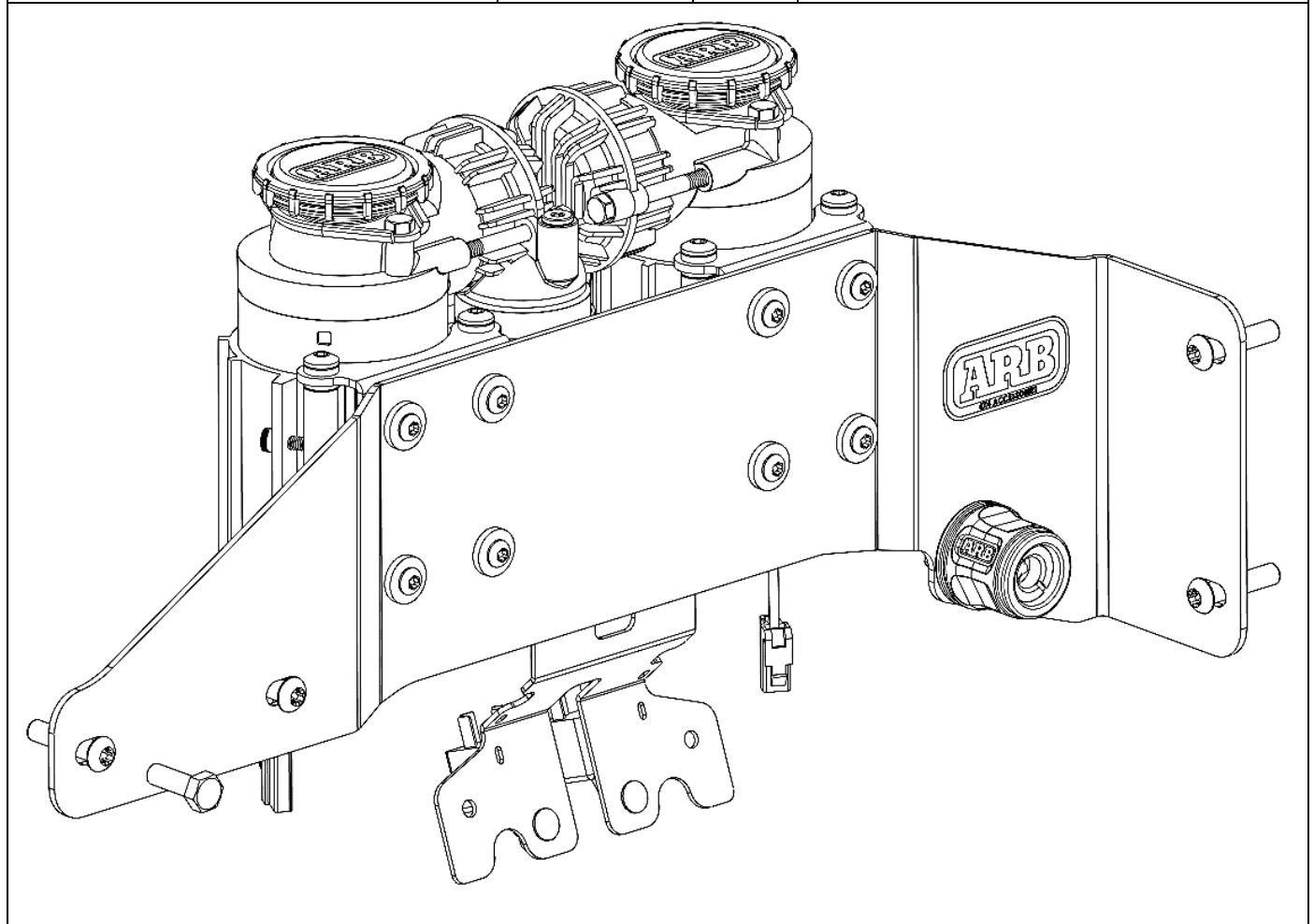

FITTING PROCEDURE



TUB PREPERATION

1. Remove all internal tub accessories and standard components.

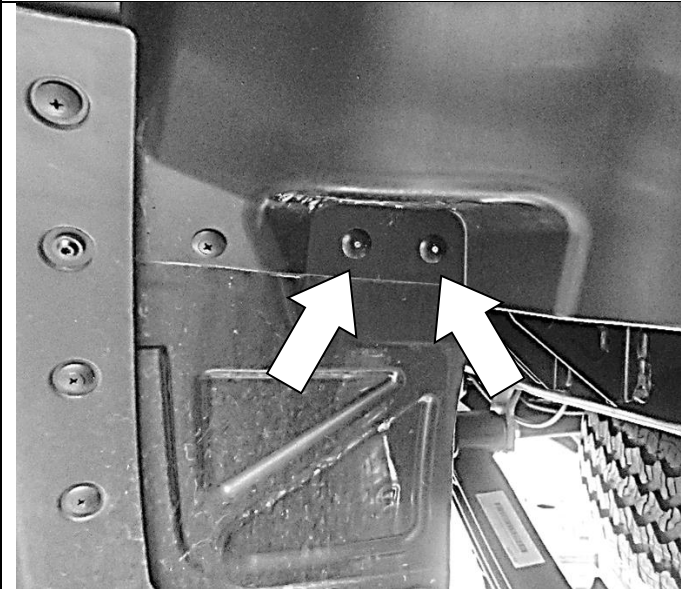

WHEEL ARCH LINER

2. Use a pin punch to knock out the steel pins in the large headed pop rivets shown at the rear of the RHS wheel arch liner.
3. Drill out the pop rivets using a $\text{Ø}6.5\text{mm}$ drill.



4. Remove four screws from the rear RHS wheel arch liner.



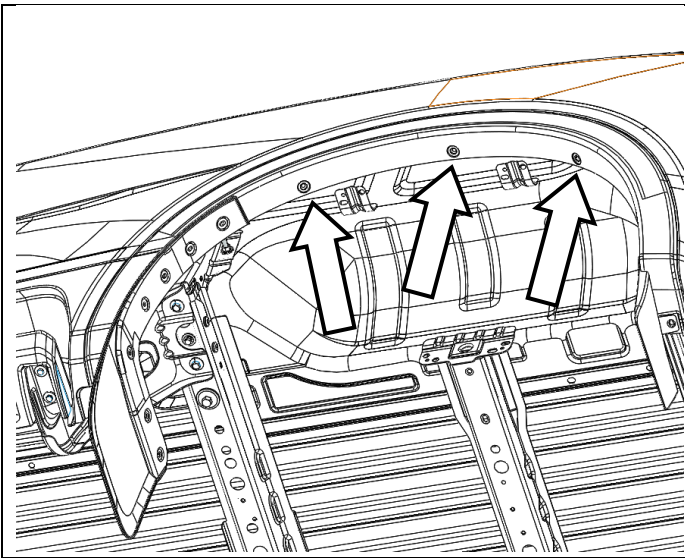

5. Remove the three screws from the wheel flare as shown.

Do not remove wheel flare.

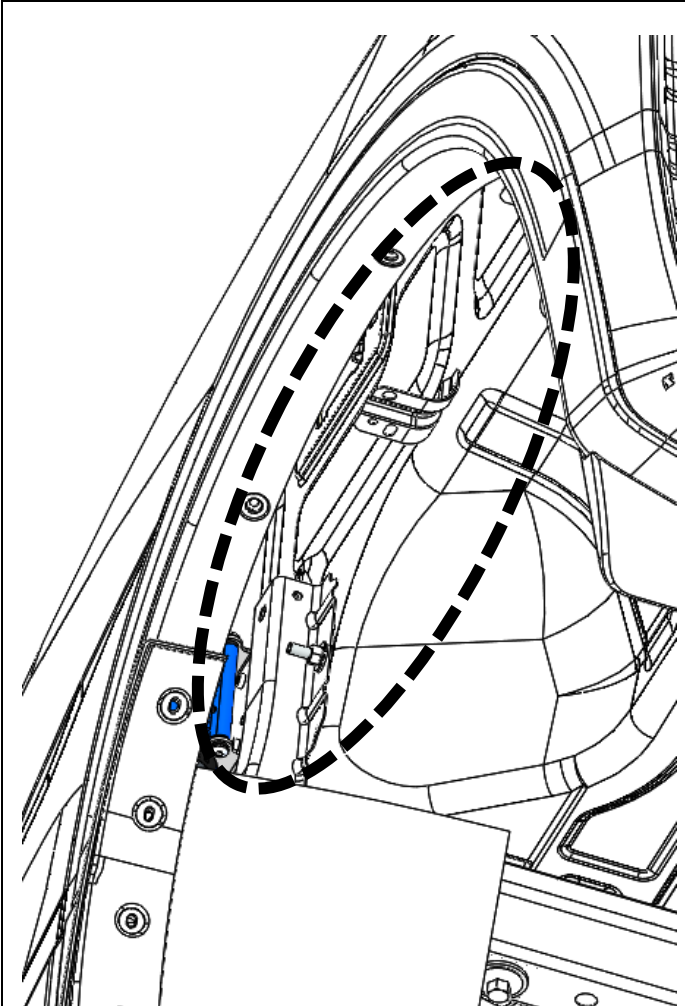

6. Pull the wheel arch liner away and down from the wheel arch flare to gain access between the tub and outside of vehicle.



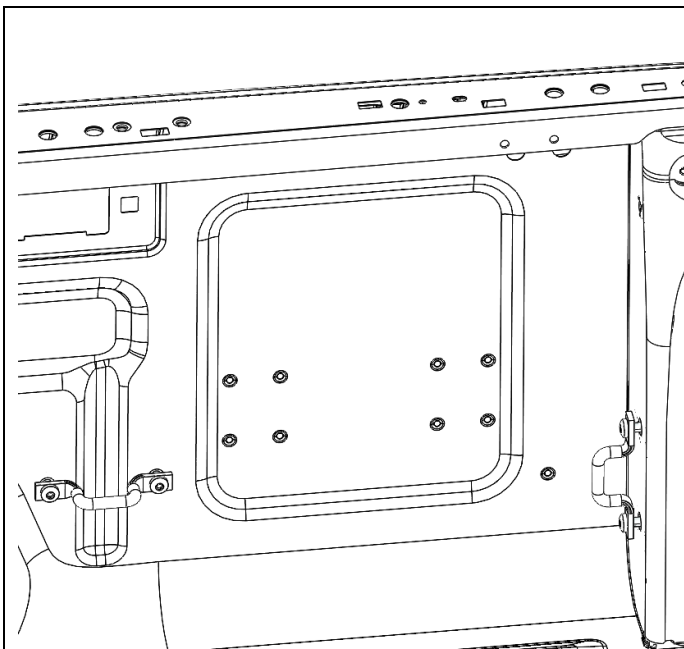

7. Inside the rear tub there are eight depressions on the RHS behind the wheel arch.
8. Centre punch each position as shown and drill through each point using a $\text{Ø}5\text{mm}$ drill.

NOTE: Each hole must be deburred and have paint applied.



9. Using a step drill, open these eight locations to $\text{Ø}10.0\text{mm}$.
10. Drill out the hole shown to $\text{Ø}30\text{mm}$ using a step drill.

ARB RECOMMENDS FITTING AT FIRST INSTALL MANIFOLD KIT 171503

If not fitting manifold, skip to Step 15

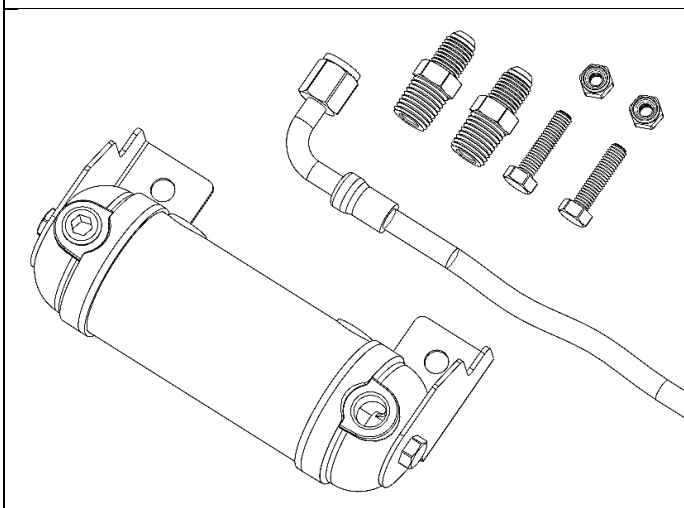

11. Prepare 171503 manifold kit (not included).

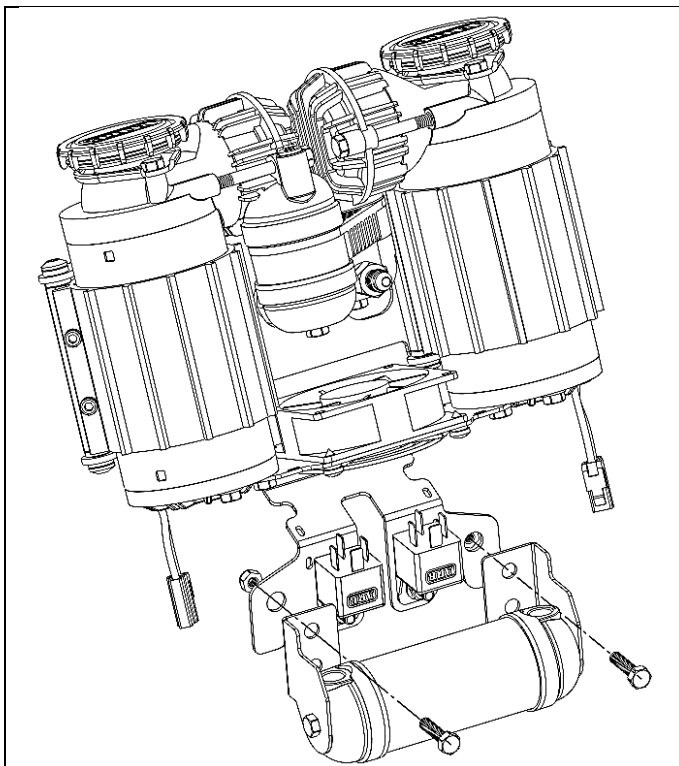

12. Fit the manifold to the compressor assembly using two M6x25 screws and M6 Nylocs included in the manifold kit.

 M6 – 9Nm

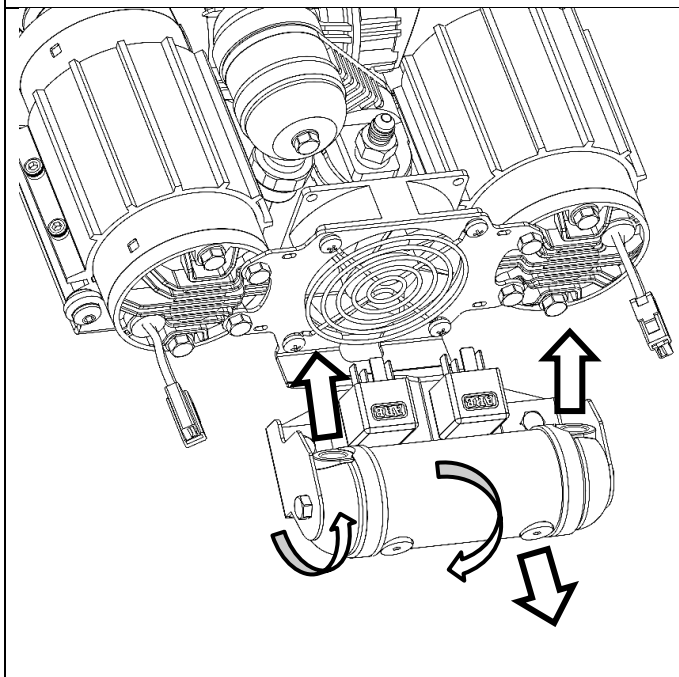

13. Loosen the bolts on the manifold brackets and orientate the manifold body and cap outlets to the directions shown.

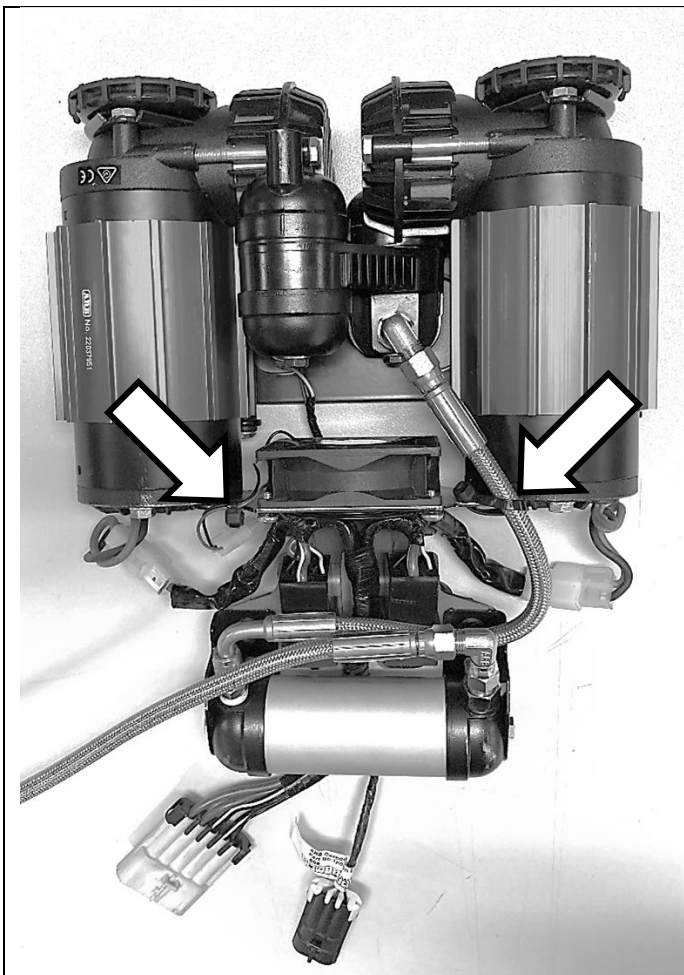

14. Fit 500mm braided hose incl. with the compressor and fittings to manifold.

Fit 270mm braided hose and fittings incl. with manifold kit to connect manifold to compressor in the configuration shown.

Secure the fan wire and compressor-manifold braided hose (270mm) at the two points shown using cable ties.

Apply LOCTITE THREAD SEALANT 569 to each connection.

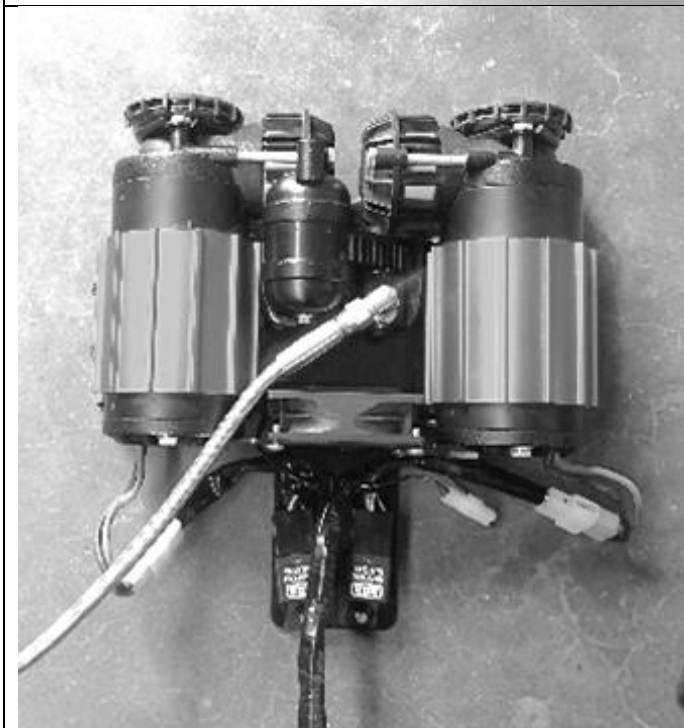

IF FITTING WITHOUT MANIFOLD KIT

15. Fit 500mm braided hose to elbow fitting using LOCTITE THREAD SEALANT 569.

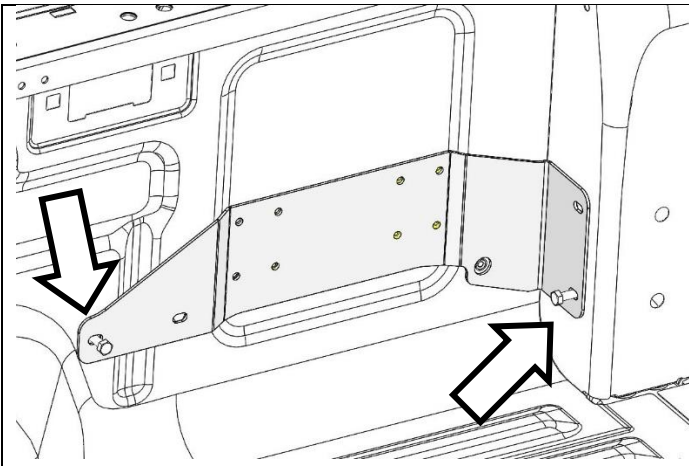

16. Using two M8 hex bolts, attach the support bracket to the OE tie down mounts.

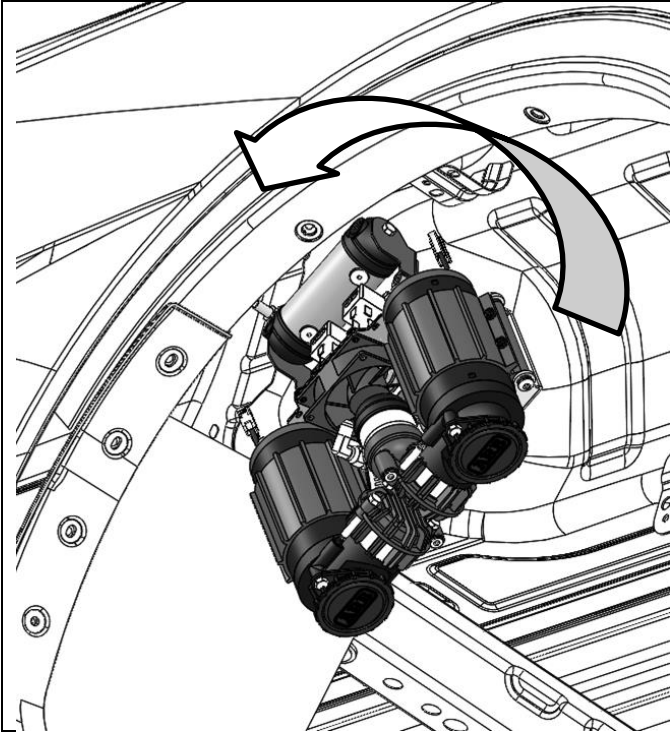

17. To fit compressor, insert into the fitting cavity with the manifold facing up and filters facing down as shown.

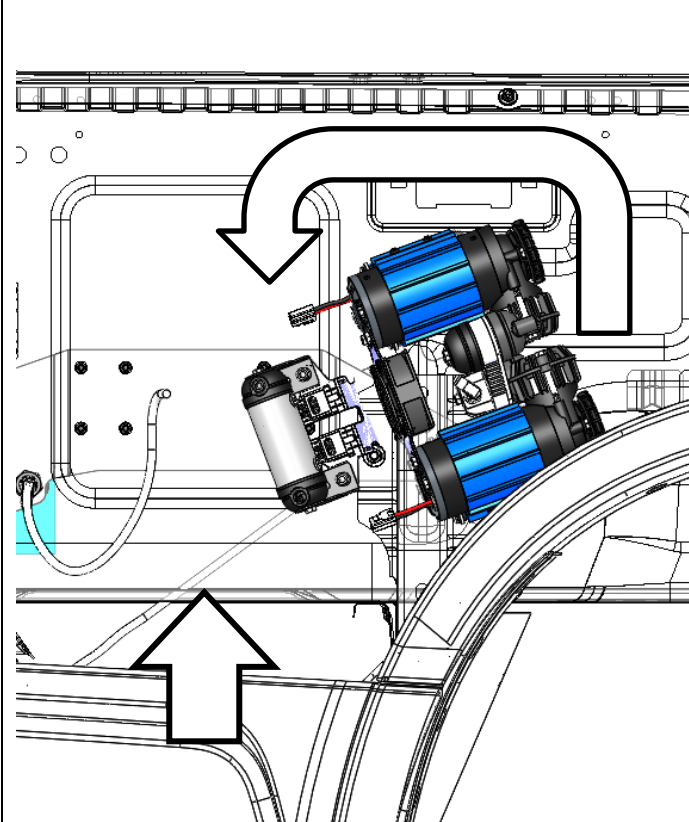

18. Once compressor is inserted rotate the compressor anti-clockwise and gently lower into position.

A second person will be required to support the compressor from underneath the rear side step.

Fitting position is shown below.

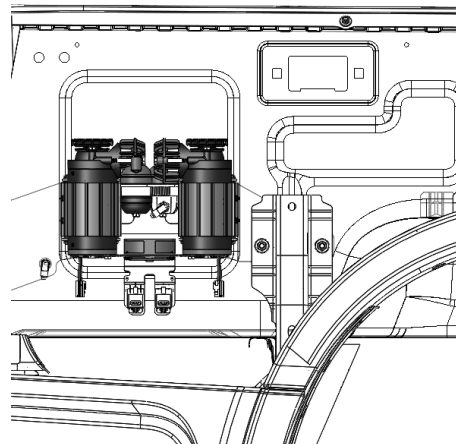

19. With the help from a second person, fit the top two corners with M6 BHD screws and washers through the mount and align into the compressor mounting points.

20. Once these are mounted, fit the remaining six M6 BHD screws and washers and tighten all eight to spec.

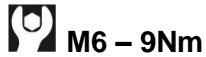

21. Remove the two M8 bolts and discard.

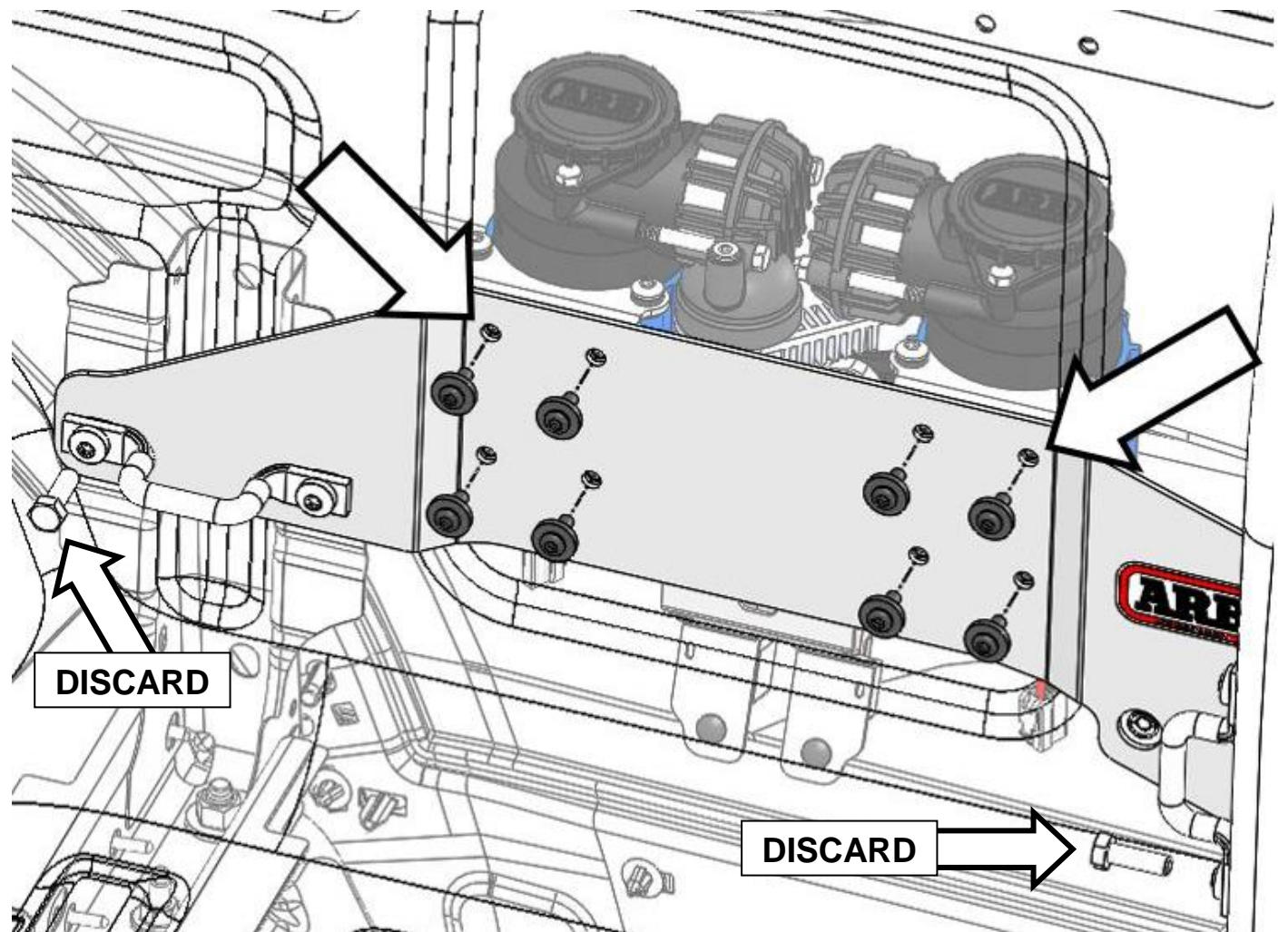

**IF THERE IS NO TUB LINER OR DRAWERS,
CONTINUE FROM STEP 22.**

**IF THERE IS A TUB LINER SKIP TO
STEP 26.**

**IF DRAWERS ARE TO BE FITTED
CONTINUE FROM STEP 33.**

VEHICLES NOT EQUIPPED WITH TUB LINER OR DRAWERS

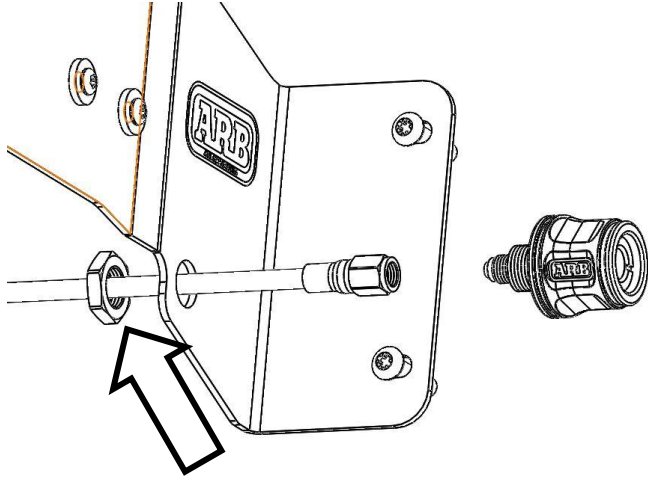

22. Remove the nut from the air chuck and place over the air hose inside the rear guard. Feed the hose through the hole in the body and mounting bracket.

 M8 – 22Nm

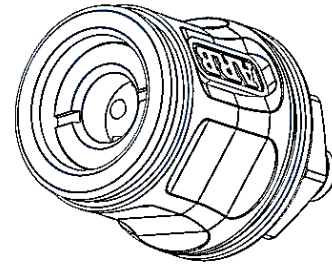

23. Using LOCTITE THREAD SEALANT 569, tighten the air chuck onto the hose.

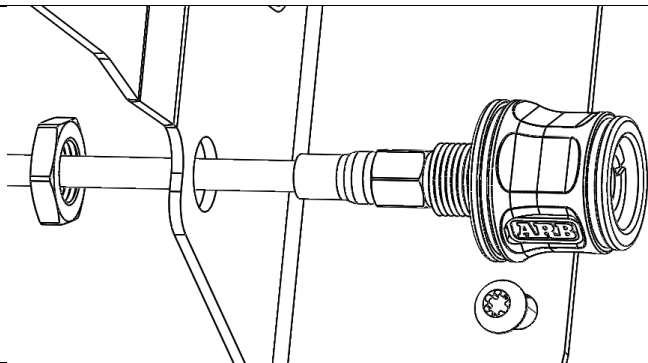

24. Feed the hose back into the hole and tighten the retaining nut for the air chuck.

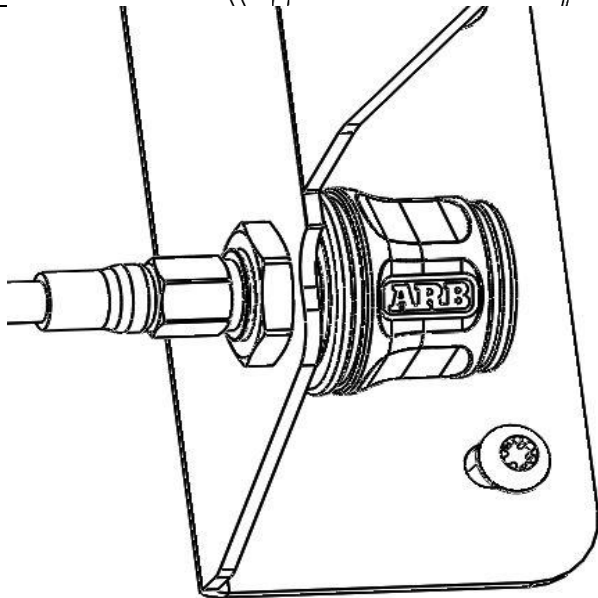

25. Using the original four M8 Button head fasteners, attach the OE tie down points to the side and rear. Torque to spec.

 M8 – 22Nm

CONTINUE FROM STEP 36

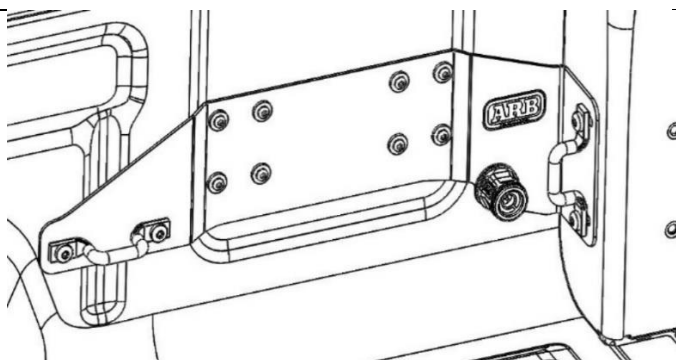

VEHICLES EQUIPPED WITH TUB LINER

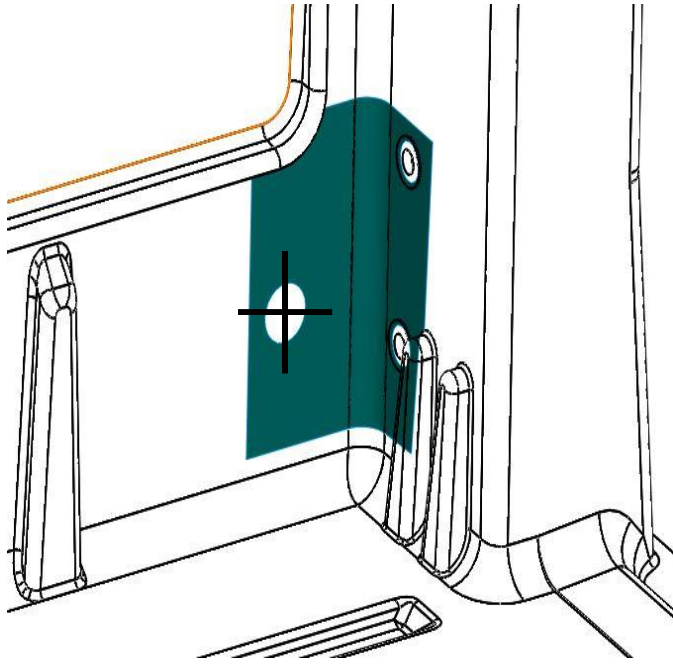

26. Align the template provided and mark out the hole on the tub liner, drill to **Ø18mm** using a step drill and deburr the hole.

27. Reinstall the tub liner only to vehicle.

28. With the tub liner RHS pulled away from the vehicle, feed the air line through the hole in the tub and mounting bracket.

29. Remove the nut from the air chuck and place the nut over the air line then continue to feed through the tub liner.

30. Using LOCTITE THREAD SEALANT 569, tighten the Air Chuck to the hose.

31. Tighten the nut so the air chuck is mounted to the tub liner.

32. Refit the tub liner corner and fit the OE tie downs using four M8 BHD fasteners per side.

 **M8 – 22Nm**

CONTINUE FROM STEP 36

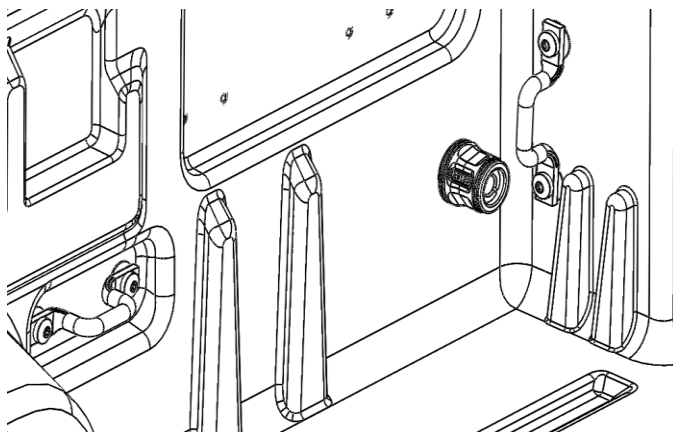
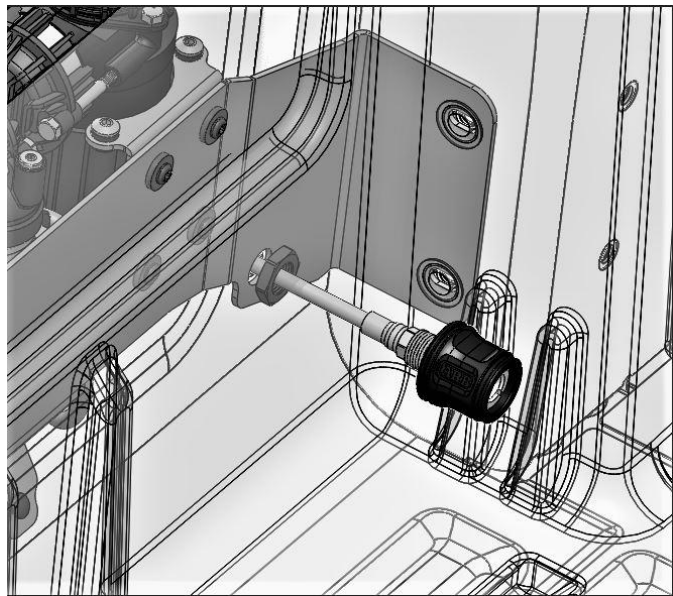

VEHICLES EQUIPPED WITH DRAWERS

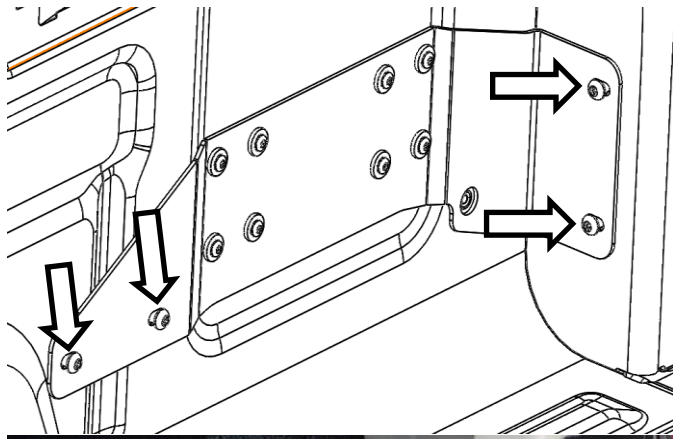

33. Fit four M8 Button head fasteners and tighten to spec.

 M8 – 22Nm

34. Once drawers are fitted, cut out the appropriate holes in the side panel and fit 3501051 (not included) following fitting instructions provided in kit.

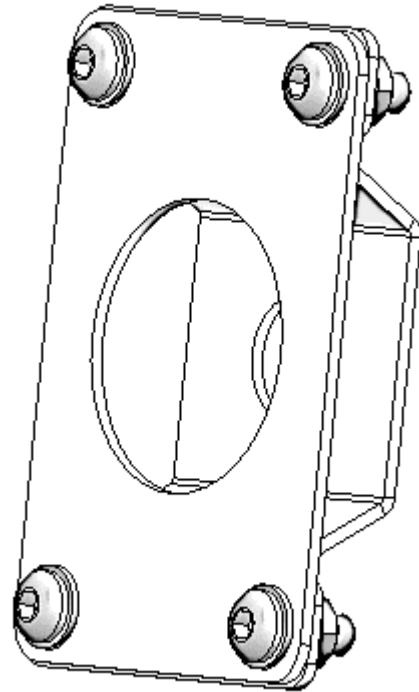

35. Feed the hose through the body and mount, then using LOCTITE THREAD SEALANT 569 tighten the hose to the air chuck.

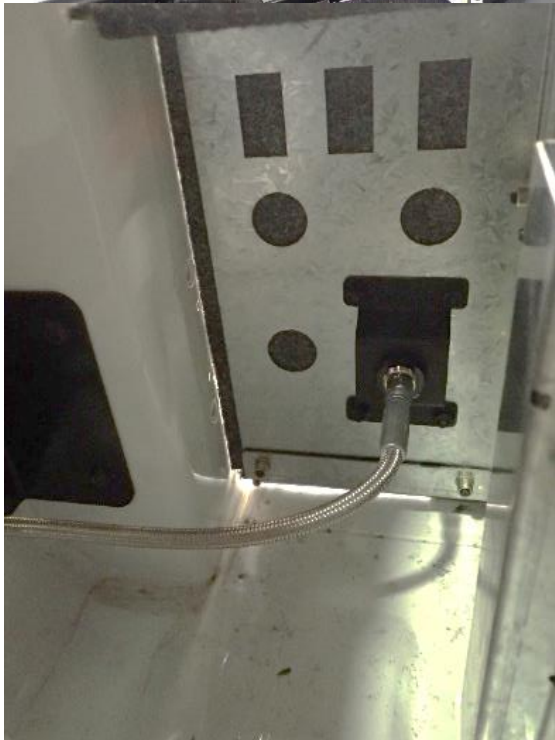

36. At this point, the harness can be installed. Please study the layout of this harness (Part #6821428) and the connectors as these will be referenced throughout the harness install procedure.

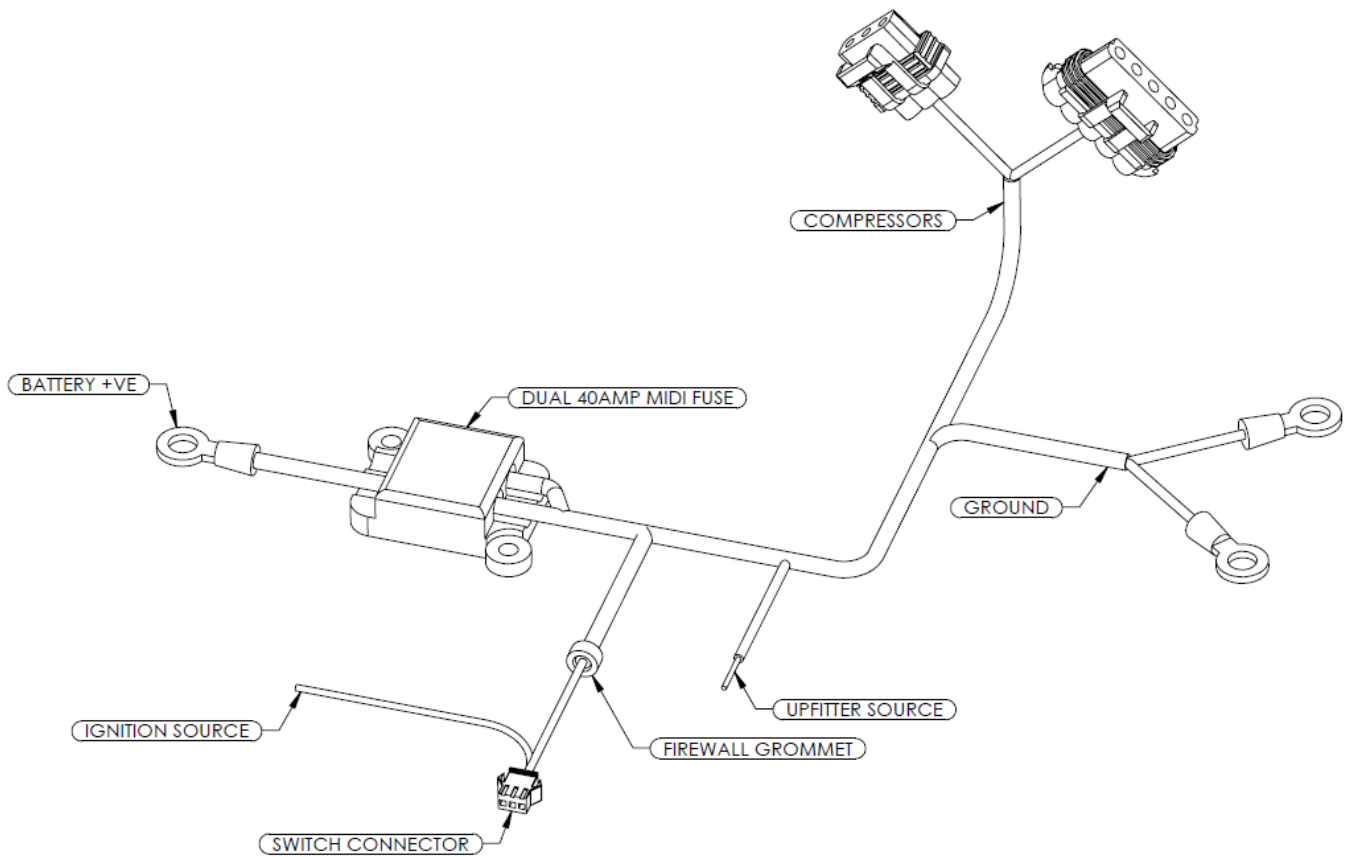

37. Disconnect the negative battery terminal from the battery.



38. Locate the harness trunk with connectors labelled 'COMPRESSORS', 'GROUND' & 'UPFITTER SOURCE'.

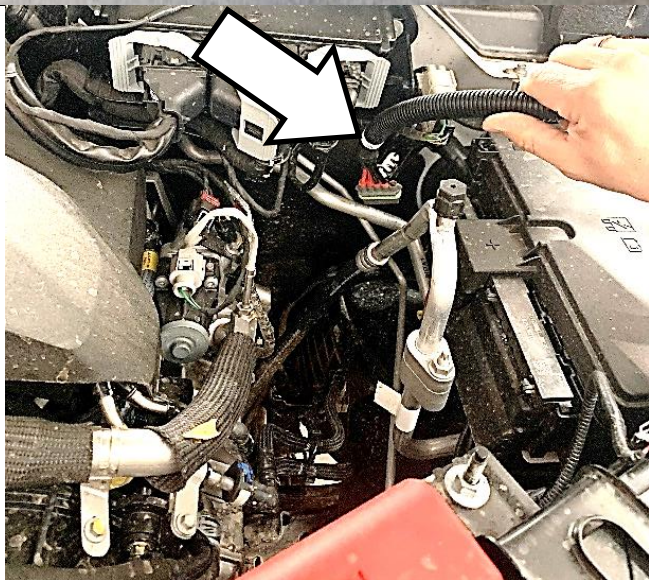

39. Take harness trunk and route harness to the left hand side, in front of firewall.

Ensure there is plenty of length to connect the ring terminal to the battery positive and secure the fuse holder.

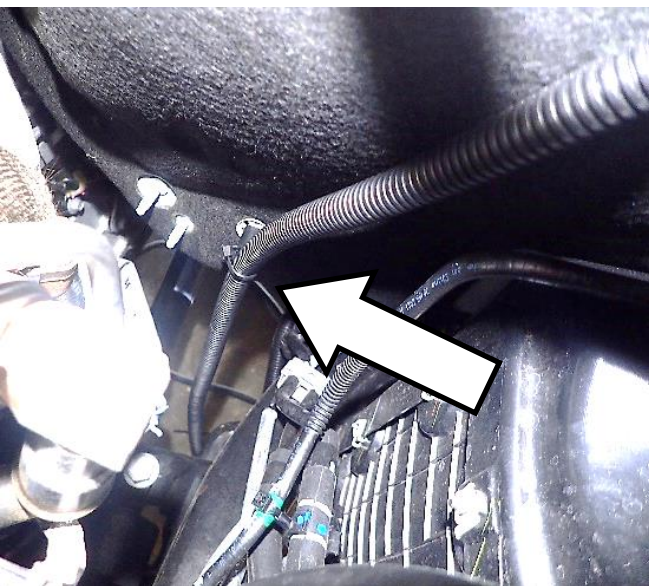

40. Supplied in the accessories bag is a stud mount cable tie. Connect this cable tie to the harness and push onto the stud protruding from the firewall.



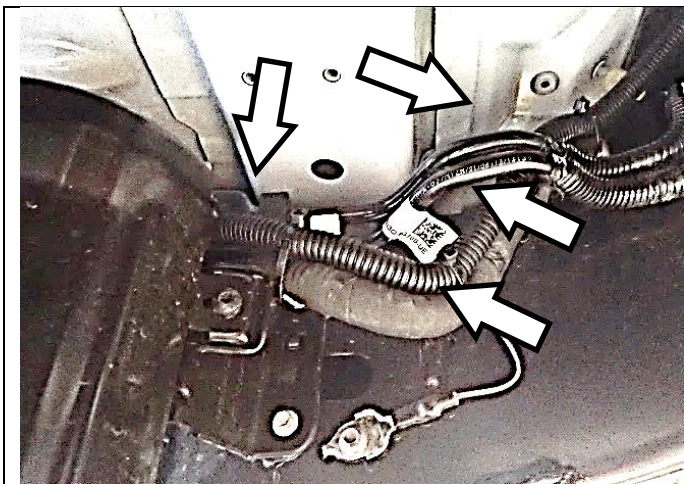

41. Lift the vehicle on a hoist, ensuring vehicle is safe and secure.
42. From underneath the vehicle, locate harness trunk previously routed in front of firewall.
43. Route harness along existing cable, behind the fuel lines.
44. Secure with cable ties as shown.



45. Route harness behind fuel reservoir.
46. Secure with cable ties on existing vehicle harness as shown.

47. Route harness along chassis rail.
48. Secure with cable ties as shown.

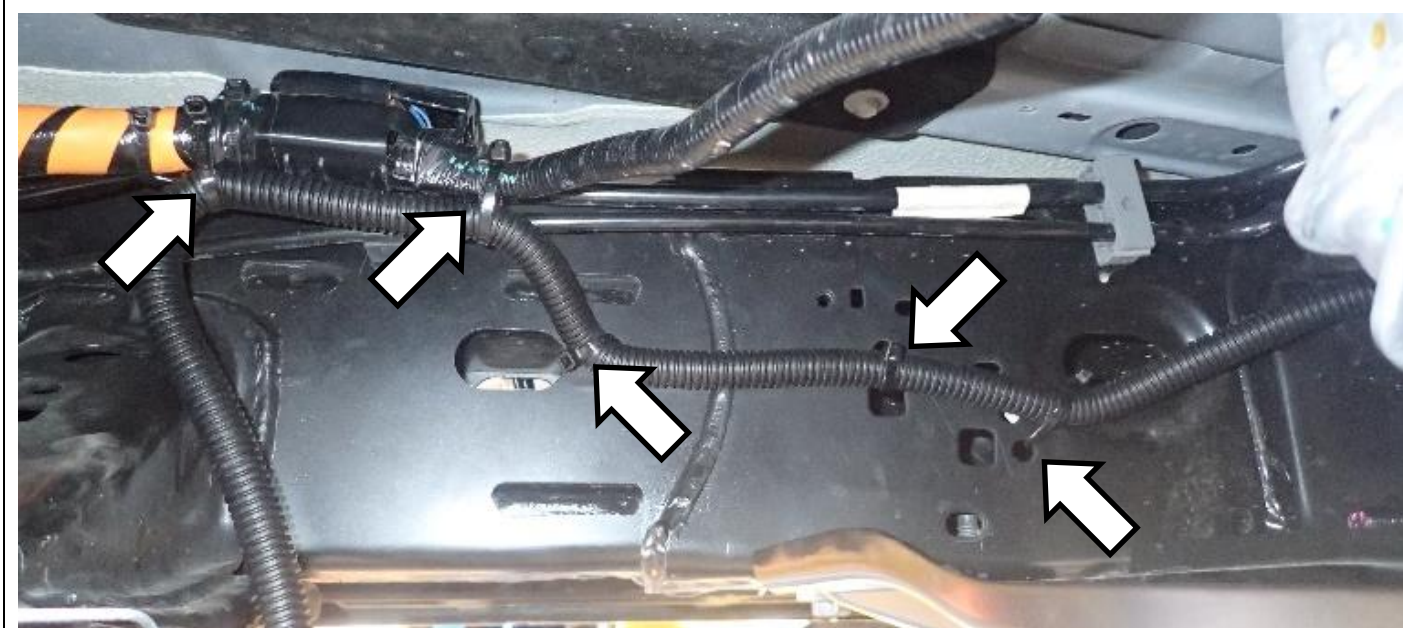



- 49. Route harness above fuel tank.
- 50. Secure with cable ties onto existing vehicle harness alongside chassis rail.
- 51. Continue routing harness along existing vehicle harness and secure with cable ties as necessary.



- 52. Remove vehicle spare tyre from beneath the vehicle tray.

The tools are located under the vehicle seat and are inserted adjacent to the vehicle rear number plate.



- 53. Route harness along existing vehicle harness above spare tyre carrier.
- 54. Secure with cable ties as required.

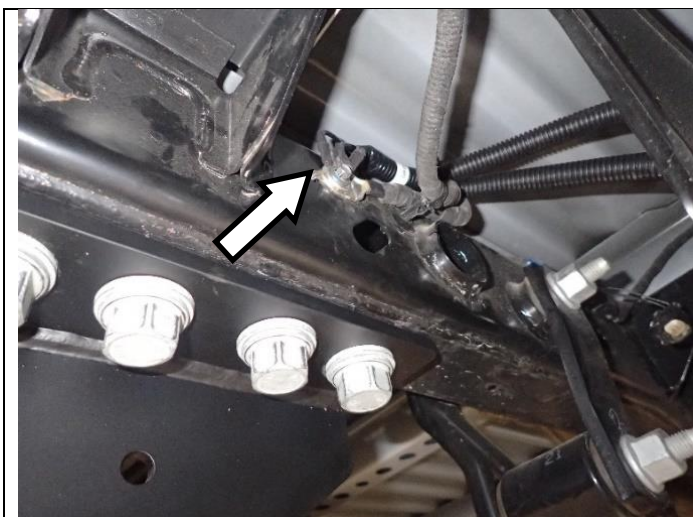

55. Find the existing ground point on the outside of the right hand chassis rail.
56. Remove ground bolt from chassis.
57. Install the two compressor ring terminals labelled 'GROUND' as shown.
58. Reinstall ground bolt to secure ground terminals.

 M6 – 9Nm



59. Install two connectors labelled 'COMPRESSORS' into compressor mating connectors.
60. Secure all loose harness trunks with cable ties.



VEHICLES WITH UPFITTER SWITCH PANEL.

For vehicles fitted with Upfitter switch panel, complete the following STEPS. Otherwise continue to STEP 65.

61. On the harness, locate unterminated wire labelled 'UPFITTER SOURCE'.

This is located to the rear of the left hand chassis rail.

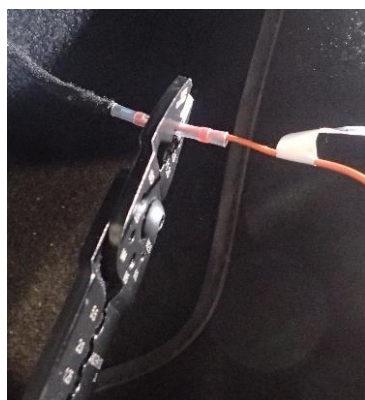

62. Locate vehicle Upfitter wire to rear of left hand chassis rail.

Get the crimp joiner supplied in the ARB harness kit. With a crimping tool, join the vehicle Upfitter wire with the harness wire labelled 'UPFITTER SOURCE'.

Using a heat gun, apply heat to secure and seal the join.



63. Locate the harness connector labelled 'SWITCH CONNECTOR' and wire labelled 'IGNITION SOURCE'.

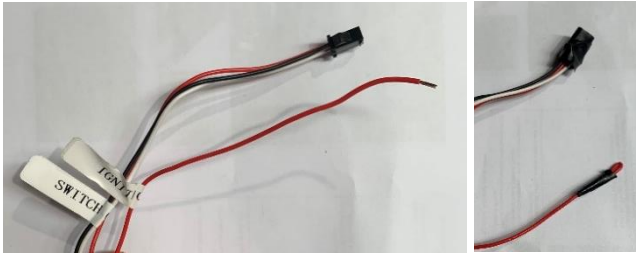

64. Tie back and cover with tape the 'SWITCH CONNECTOR' and wire 'IGNITION SOURCE'.

These wires are not required for Upfitter switch panel vehicles.

Bundle wires and secure onto harness trunk with cable ties.

Continue to STEP 97.



VEHICLES WITHOUT UPFITTER SWITCH PANEL.

65. On the harness, find connector labelled 'SWITCH CONNECTOR'.

66. Find a short length of plastic pipe or similar. On the end of the pipe, cut a sharp point.

67. Join the 'SWITCH CONNECTOR' to the pipe with electrical tape. Ensure the tape removes all sharp edges to ensure the taped connector will pass through the firewall grommet with ease.

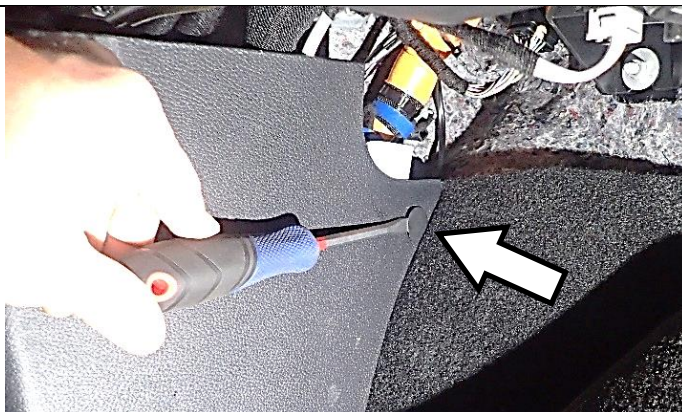

68. From inside the vehicle left hand side, to the left of the foot well, find and remove the christmas tree plug as shown.

A screwdriver may assist to lever the plug out.

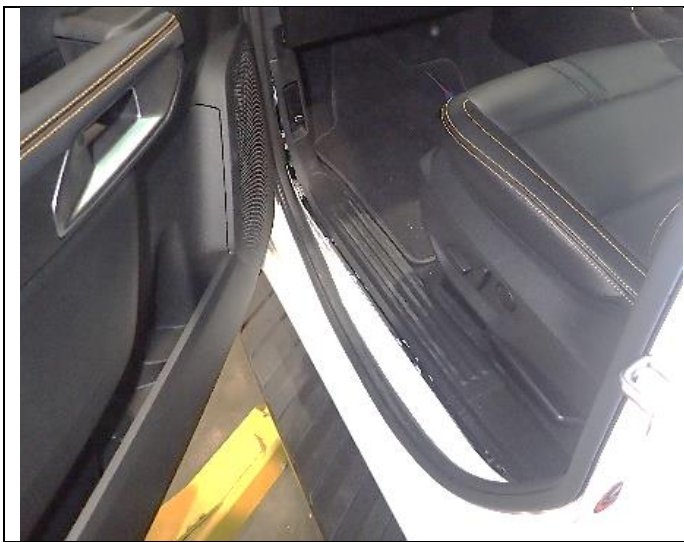

69. Lift and remove the rubber seal surrounding the left hand side sill panel.



70. Remove door sill panel as shown. This can be removed by lifting the sill panel and then rotating up.



71. Locate firewall grommet located behind the passenger side fuse box.



72. With a sharp blade, cut and remove the nipple from the firewall grommet. Spray the pipe and taped connector with lubricant. Feed pipe through firewall grommet nipple. From inside the vehicle, pull the pipe and 'SWITCH CONNECTOR' through the firewall grommet.

Remove tape and pipe leaving the 'SWITCH CONNECTOR' inside the vehicle.

73. Pull wire labelled 'IGNITION SOURCE' into the vehicle as well.

74. Secure the harness in the engine bay with cable ties.

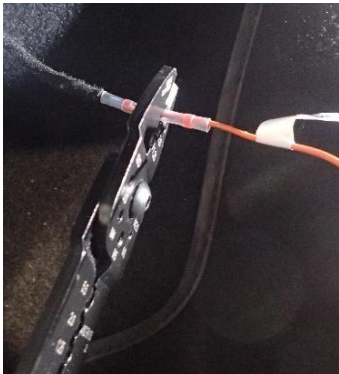

75. Behind the door sill panel, identify the crimp joiner supplied in the ARB harness kit. With a crimping tool, join the vehicle wire labelled "RUN START" with the harness wire labelled 'IGNITION SOURCE'.

Using a heat gun, apply heat to secure and seal the join.



76. Remove vehicle glove compartment.

To remove, the two clips on each side of the glove compartment must be released as shown.



77. Behind the glovebox compartment, route harness on existing vehicle harness as shown.

Secure onto existing harness with cable ties.

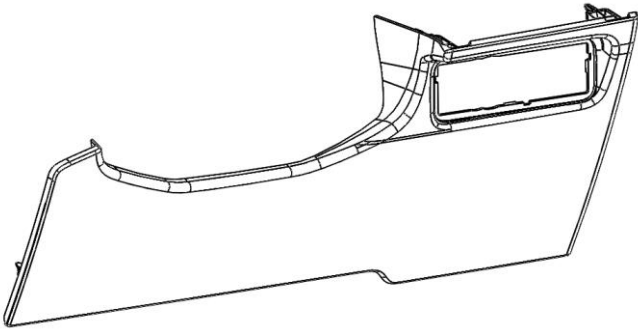

BELOW THE STEERING COLUMN

78. Below the steering column and starting from the LHS, disconnect the retaining clips and lower the Fuse box cover

79. Once lowered, unplug the switch loom and then remove the 2 fasteners to remove the panel from vehicle.

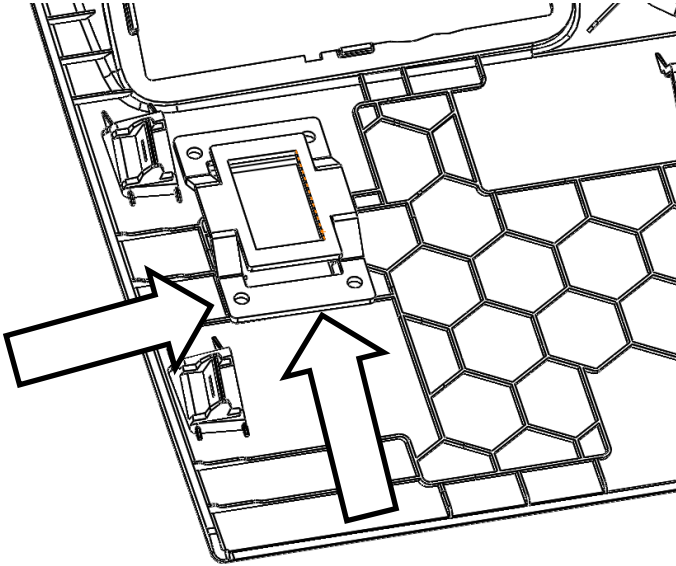

80. Align the switch mounting bracket to the edges on the back side of the panel as shown.

81. Drill four Ø4.5mm holes using the bracket as the drilling guide.

Carefully deburr the holes.



82. Place the switch cover plate on the front surface and align with the M4 Button head screws.

83. Carefully scribe the panel using the plate as the guide.





84. Using a multi tool, cut out the scribed area and deburr all the edges.

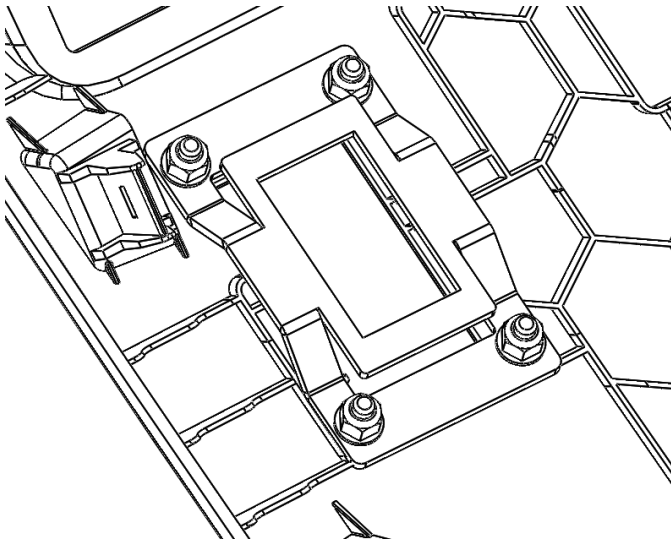

85. Use the four M4 Button head screws to locate the cover plate and switch mount, then tighten using the four M4 washers and four M4 Nyloc nuts.

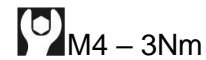

86. Locate the ARB rocker switch supplied with this compressor kit and click into place.

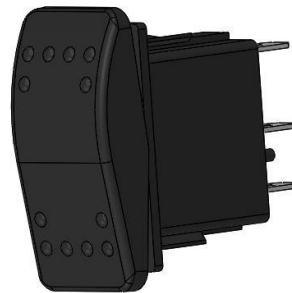



87. Re-install the fuse box cover panel and connect OE loom.



88. Follow the labeled ends to connect the ARB harness (part number 6821430) to the rocker switch.

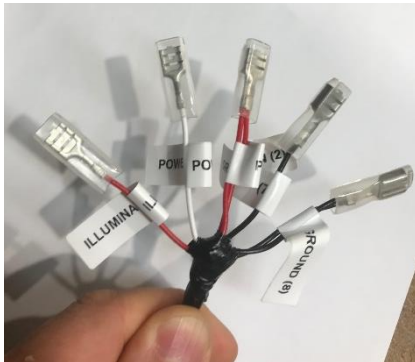

- I. GROUND (8) – illumination ground 1
- II. GROUND (7) – illumination ground 2
- III. POWER IN (2) – from ignition supply
- IV. POWER OUT (3) – to ARB compressor
- V. ILLUMINATION (6) – from ignition supply



89. Route ARB universal switch cable along the frame under the steering column. Secure with cable ties ensuring the harness is not contacting any sharp or hot objects.

90. Feed ARB universal switch cable behind the vehicle centre console as shown.

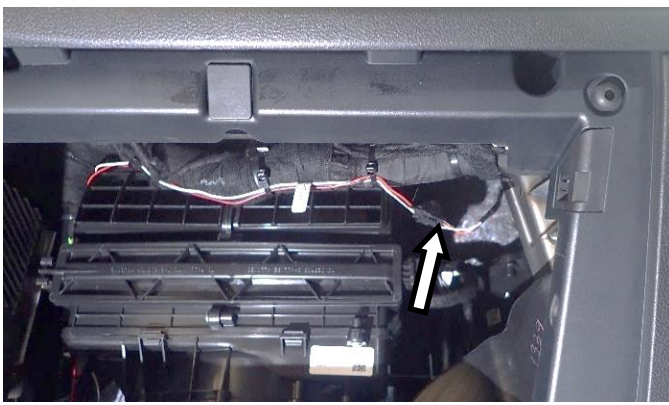

91. On the passenger side of the vehicle, connect the ARB universal switch connector into harness connector labelled 'SWITCH CONNECTOR'.



92. In the passenger side footwell, bundle all cables to existing vehicle harness.

Secure all with cable ties.



93. Refit the passenger side footwell panel. Press at various locations to ensure all clips are engaged.

94. Refit the footwell christmas tree plug.

95. Reinstall the rubber seal. Press at various locations to ensure all is secure.

96. Refit glove box into vehicle.



97. On positive battery terminal, remove one of the terminal nuts.



98. On the harness, locate the ring terminal with label 'BATTERY +VE'.

99. Install the 'BATTERY +VE' ring terminal on the terminal stud.

Secure ring terminal onto stud with nut.

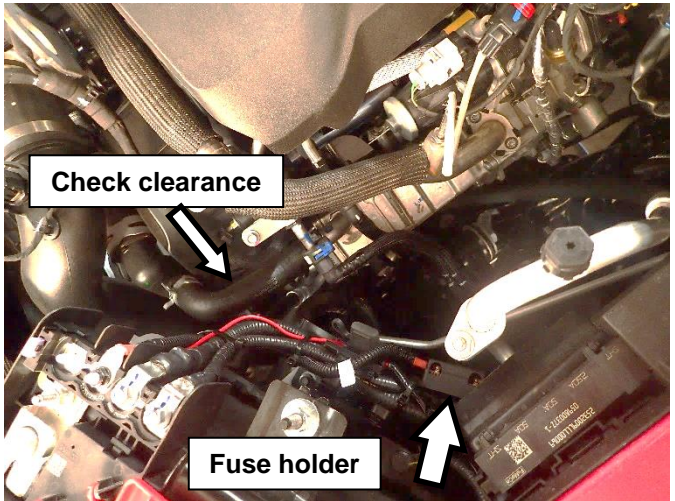

100. Position DUAL 40AMP MIDI FUSE holder onto existing harness as shown.

101. Secure harness to existing vehicle harness with cable ties.

Ensure there is minimum 20mm clearance between compressor harness and engine components, particularly in the position shown.



102. Refit the RHS wheel arch liner using the scrivenets removed in Steps 4 and 5.

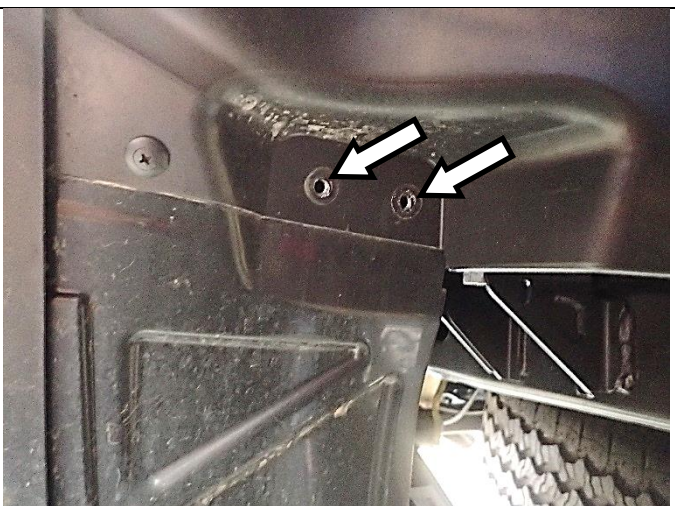

103. Install the provided pop rivets and two M6x18x3 flat washers into the locations of the removed pop rivets from Steps 2 and 3.

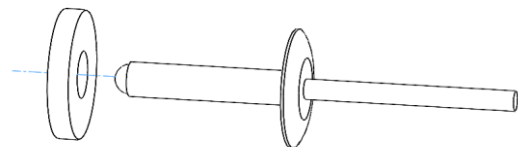



104. Reinstall the battery negative terminal.

105. Test and evaluate.

The ARB compressor has a pressure switch which deactivates the compressor once the required pressure is reached. This pressure switch is included in the table below. For testing, an air gun is required to reduce pressure and thus *close* the pressure switch.

Vehicle ignition state	Upfitter switch state, or ARB switch state	Compressor pressure switch state	Compressor state
ON	ON	ON	ON
ON	ON	OFF	OFF
ON	OFF	ON	OFF
ON	OFF	OFF	OFF
OFF	ON	ON	OFF
OFF	ON	OFF	OFF
OFF	OFF	ON	OFF
OFF	OFF	OFF	OFF

WITHOUT TUB LINER

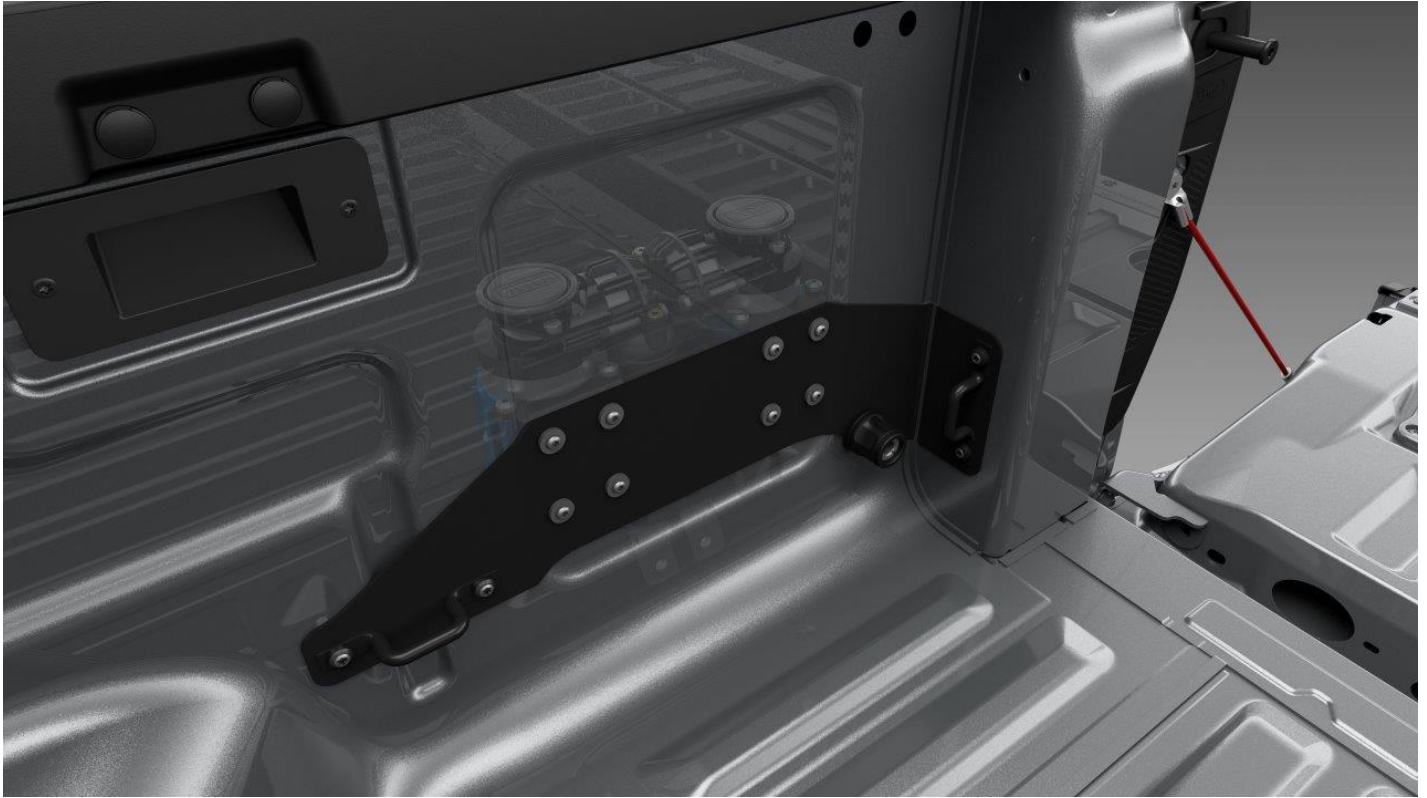

WITH TUB LINER

