



**4X4 ACCESSORIES**

# FORD RANGER 22+ HARDLID FITTING INSTRUCTIONS

## 2 OF 2

**Instruction # 10058238**

Ford Ranger 22+	Fitting Kit Part # 10057976
Compatible: Double Cab XL, XLT, XLS, Sport & Raptor	Not compatible: Wildtrack, Space Cab & Single Cab

# FORD RANGER 22+ FITTING INSTRUCTION

**READ INSTRUCTIONS CAREFULLY BEFORE COMMENCING THIS ACTIVITY.**

## General Notes

To aid in installation the correct order of installation needs to be followed:

1. Install all electrical components first (1 of 2) (electrical components are supplied separately)
2. Install Vehicle Tub Sealing Kit
3. Install vehicle tub protective products such as tub liners\*
4. Install styling bar onto HardLid
5. Install the HardLid Fitting Kit (2 of 2)
6. Install the HardLid (2 of 2)
7. Install any additional accessories such as roof racks.

*\*HardLid is compatible with under rail and Sport Guard style tub liners. Some trimming may be required. OEM liner compatibility cannot be guaranteed. Please contact your dealer for more information.*

- HardLid is supplied with 400N Gas Struts which are suitable for an unloaded lid. Recommended maximum loading of 25 kgs when opening the lid. If you require your lid to remain open whilst loaded, you will need to purchase a Heavy Load Strut Upgrade Kit which is available through your local dealer. Please use one of the following part numbers as a reference when contacting your dealer:

ARB NZ Part #	ARB AU Part #	Gas Strut N	
10056207	176202	450N	
10056209	176201	500N	

- Read through the fitting instructions before installation of accessory.
- Check that the contents of the Fitting Kit are complete and undamaged.
- If any contents of the Fitting Kit are found incomplete or damaged they must be replaced using the specified accessory components.
- Always install the accessory following the fitting instructions. Failure to do so may cause damage to the vehicle or the accessory and void the warranty.
- Ensure all recyclable discarded vehicle/accessory components and packaging are disposed following local recycling regulations.
- Safely store and protect any removed vehicle components.
- Ensure all bare metal surfaces are protected using Automotive Bare Metal Primer and touch-up paint.
- Remove all metal swarf and dust from all vehicle surfaces.
- Ensure all fasteners are torqued to the specifications as per instruction.
- Apply any adhesives to the vehicle only when the surface temperature is between 20°C to 40°C.
- **Bedliner:** Recommended rust preventative solution be applied to vehicle surfaces before installation.

## General Vehicle and Accessory Warranty Notes and Cautions



- For correct installation and proper operation of the vehicle and accessory we recommend this accessory is fitted by a qualified Technician.
- During the accessory fitment ensure all automotive safety practices and regulations are followed.
- Do not modify the vehicle in any way other than specified in these Accessory Fitting Instructions as this may void the warranty.



## Safety Notes

- Check that all work practises comply with safety standards.
- It is advisable to seek assistance from another person when lifting heavy components.
- While using power tools ensure safe procedures are followed.
- Appropriate clothing & PPE must be worn.

# FORD RANGER 22+ FITTING INSTRUCTION

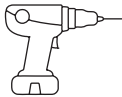
**READ INSTRUCTIONS CAREFULLY BEFORE COMMENCING THIS ACTIVITY.**

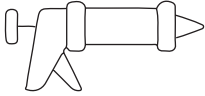





No.	Description	Image
<b>Tools Required</b>		
1	METRIC HEX KEY SET	
3	METRIC SPANNER SET	
5	CLEANING RAGS	
7	POWER DRILL & 5MM DRILL BIT	

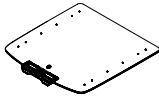

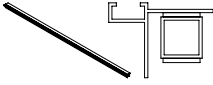
No.	Description	Image
<b>Tools Required</b>		
2	METRIC RULER	
4	CLEAR NON-ACETIC SILI-CONE	
6	TROQUE WRENCH	
8		







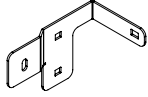
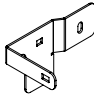



# FORD RANGER 22+ FITTING INSTRUCTION

**READ INSTRUCTIONS CAREFULLY BEFORE COMMENCING THIS ACTIVITY.**

No.	Service part No.	QTY	Image
<b>1. Sportlid</b>			
1.0	HARDLID	1	

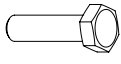
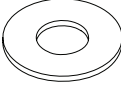
<b>2. Sealing Kit</b>			
2.0	10057605 SEALNG CHANNEL	1	
2.1	10051996 3M 94 PRIMER	2	
2.2	10051664 ISOPROPYL ALCOHOL WIPES	2	
2.3	10057892 TUB SEALING BLOCKS	1	
2.4	10054712 TAPE ANTI-ABRASION	1	
2.5	10055577 FOAM SEAL BLACK	0.2	

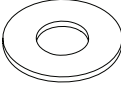
<b>3. Mounting Brackets &amp; Hardware</b>			
3.0	10057118 MOUNT BRACKET FRONT LHS	1	
3.1	10057719 MOUNT BRACKET FRONT RHS	1	
3.2	10057723 MOUNT BRACKET FRONT CMS	2	
3.3	10057722 MOUNT BRACKET CENTRE CMS	2	

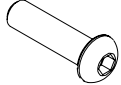
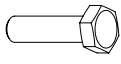
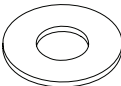
No.	Service part No.	QTY	Image
3.4	10057724 MOUNT BRACKET CENTRE	2	
3.5	10057729 MOUNT BRACKET REAR LHS	1	
3.6	10057730 MOUNT BRACKET REAR RHS	1	
3.7	10057738 SPACER M8X18X18MM	2	
3.8	10057737 SPACER M8X18X13MM	2	
3.9	10057890 SPACER M8X18X10MM	2	
3.10	10057891 M6X20MM SET SCREW	6	
3.11	10053451 WASHER FLAT M6X19X1.6MM	12	
3.12	10053338 NUT M6 NYLOC	6	
3.13	10003717 WASHER FLAT M8X19X1.2MM	40	
3.14	10053337 NUT M8 NYLOC	16	
3.15	10052186 BUTTON HEAD SCREW M8X35MM	12	
3.16	10056261 M8X30MM SET SCREW	12	
3.17	10055714 WASHER FLAT M8X24X2MM	2	

# FORD RANGER 22+ FITTING INSTRUCTION

**READ INSTRUCTIONS CAREFULLY BEFORE COMMENCING THIS ACTIVITY.**

No.	Service part No.	QTY	Image
-----	------------------	-----	-------

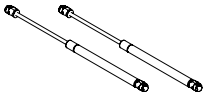

## 4. Gas Struts

4.0	10058202 GAS STRUT PAIR	1	
-----	----------------------------	---	---

Sportlid is supplied with 400N Gas Struts which are suitable for an unloaded lid. We recommend a maximum loading of 25 kgs when opening the lid. If you require your lid to remain open whilst loaded, you will need to purchase a **Heavy Load Strut Upgrade Kit** which is available through your local dealer- refer to user manual for part number information.

## 5. Mounting Rails

Note: Items 5.2 - 5.8 are pre-assembled as part of 5.0 & 5.1  
Ensure that sub assemblies contain all parts before commencing installation.

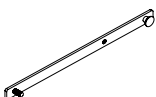
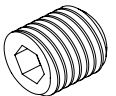
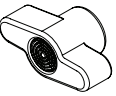
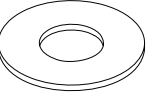
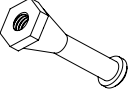
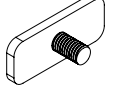
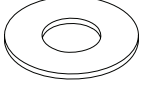
5.0	10057779 LEFT VCR ASSEMBLY FOR RAN 22+	1	
5.1	10057780 RIGHT VCR ASSEMBLY FOR RAN 22+	1	
5.2	10055552 HINGE MOUNT	2	
5.3	10055553 M8X10MM GRUB SCREW	2	
5.4	10000100 KNOB FEMALE WING M8	2	
5.5	10055714 WASHER FLAT M8X24X2MM	2	
5.6	10055550 LATCH PIN	2	
5.7	10057752 LATCH PIN LUG PLATE	1	
5.8	10003717 WASHER FLAT M8X19X1.2MM	2	







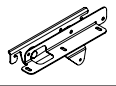
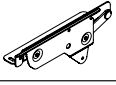
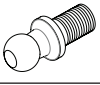
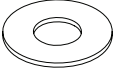

No.	Service part No.	QTY	Image
-----	------------------	-----	-------

## 6. Hinges

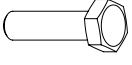
Note: Items 6.2 - 6.4 are pre-assembled as part of 6.0 & 6.1  
Ensure that sub assemblies contain all parts before commencing installation.

6.0	10057826 LEFT HINGE ASSEM	1	
6.1	10057827 RIGHT HINGE ASSEM	1	
6.2	10056199 NUT M8 NYLOC	4	
6.3	10056204 BALL STUD	4	
6.4	10003717 WASHER FLAT M8X19X1.2MM	4	

## 7. General Hardware

7.0	10053299 M8X30MM B/HEAD	6	
7.1	10003717 WASHER M8X19X1.2MM	6	
7.2	10056261 M8X30MM SETSCREW	2	
7.3	10055927 STEP SPACER	2	
7.4	10055714 WASHER M8X24X2MM	2	
7.5	10000091 SEAL	0.2	
7.6	10055835 NUT HEX FLANGE M8	2	
7.7	10053982 BLACK RIVET	8	

## 10. Miscellaneous

8.0	10055862 OWNERS MANUAL	1	
-----	---------------------------	---	---

# FORD RANGER 22+ FITTING INSTRUCTION

**READ INSTRUCTIONS CAREFULLY BEFORE COMMENCING THIS ACTIVITY.**

## OEM Bedliner Preparation

It is recommended that the bedliner be removed from the vehicle before commencing the modifications. If the vehicle is equipped with CMS mount rails these will also need to be removed.

- Using the corner radius as a guide, cut approximately 30mm away from the corner.
- Repeat for opposite side.

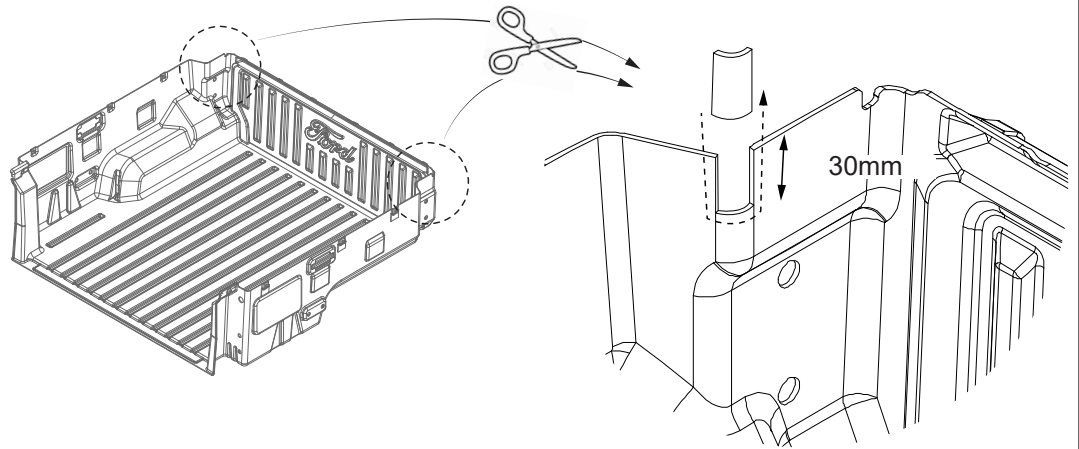

- Mark a centre point 86mm backward from the front wall and 54mm down from the top edge.
- Drill a 20mm hole.
- Repeat for opposite side.
- Debur all cut edges.

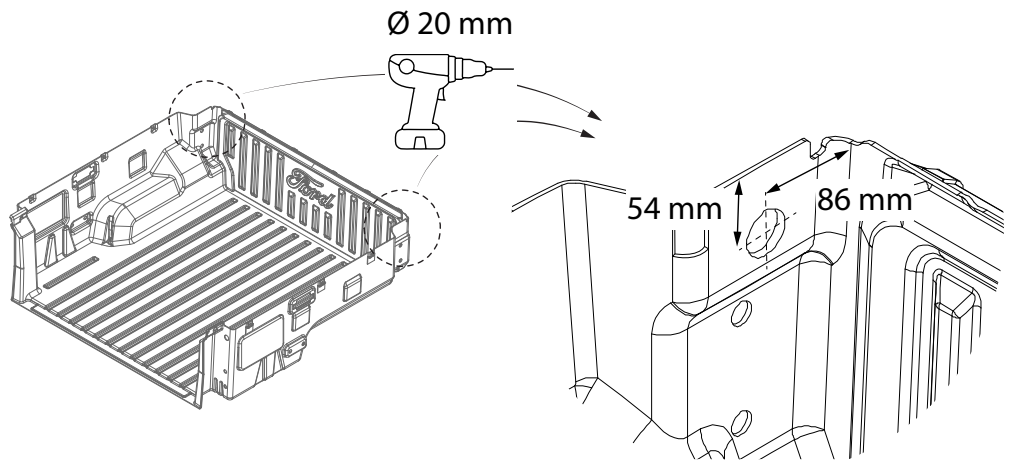

Do not reinstall the liner or CMS mount rails until the sealing (refer steps 1-7) and electrical (10058093) components have been installed.

# FORD RANGER 22+ FITTING INSTRUCTION

**READ INSTRUCTIONS CAREFULLY BEFORE COMMENCING THIS ACTIVITY.**

## Sportguard Preparation

It is recommended that the Sportguard be removed from the vehicle before commencing the modifications. If the vehicle is equipped with CMS mount rails these will also need to be removed.

- Using the corner radius as a guide, cut approximately 15mm away from the corner.
- Repeat for opposite side.

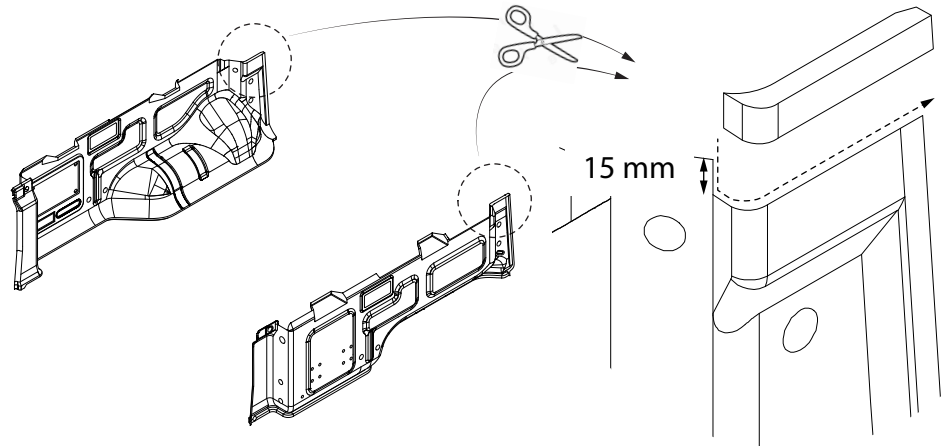

- Locate the formed crosshair on the B-surface.
- Drill a 20mm hole.
- Repeat for opposite side.
- Debur all cut edges.

Do not reinstall the liner or CMS mount rails until the sealing (refer steps 1-7) and electrical (10058093) components have been installed.

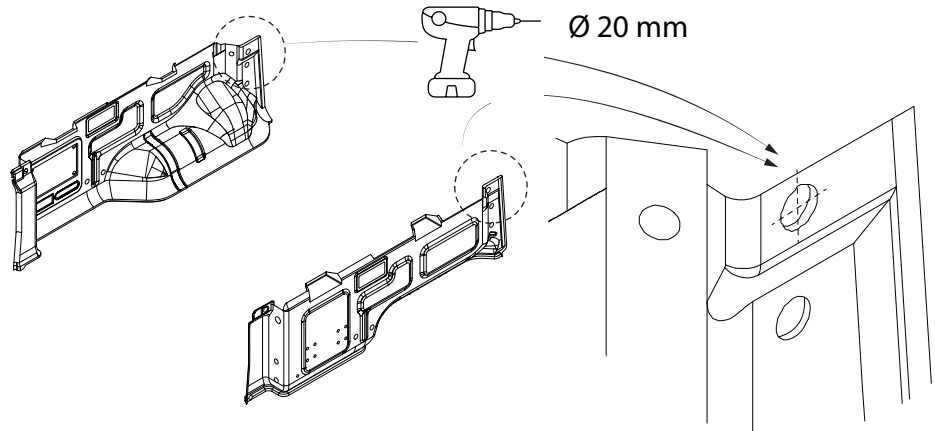

## Vehicle Preparation

- Carefully measure and mark a 30 X 150MM section at the front corner of the plastic rail cap.
- Remove and discard of the cut section to expose M8 threaded hole. Repeat for opposite side.

Note: dependant on vehicle model this step may not be required.

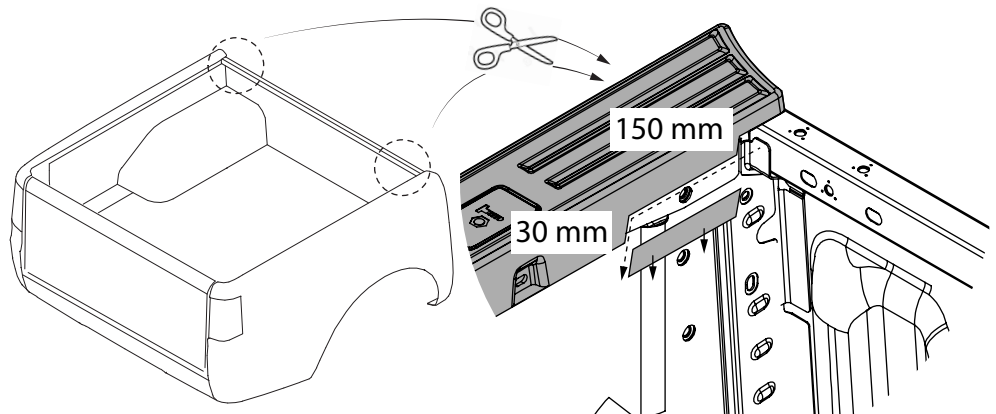

# FORD RANGER 22+ FITTING INSTRUCTION

READ INSTRUCTIONS CAREFULLY BEFORE COMMENCING THIS ACTIVITY.

## Step 1

- Thoroughly clean the top, rear and underside of the front rail using item 2.2
- Thoroughly clean the upper front corners of the deck using item 2.2.

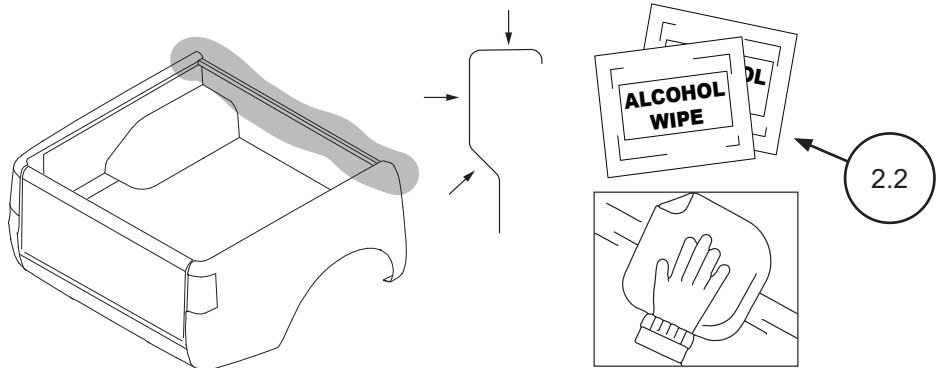

## Step 2

- Apply surface primer, item 2.1 to the entire length of the top surface of the front rail.

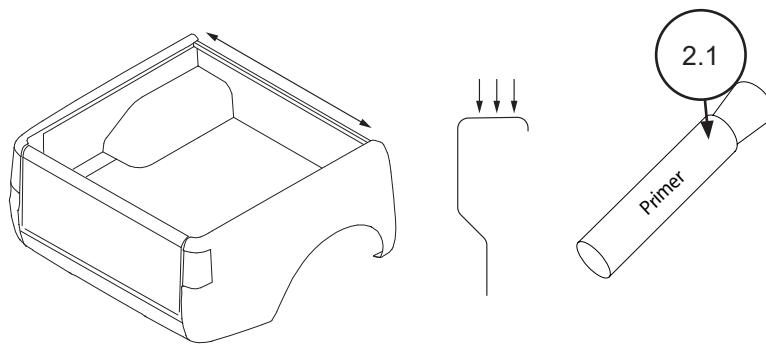

## Step 3

- Cut 5 X 25mm strips of tape, item 2.4. Cover the 5 holes along the inside face of the front rail, indicated by arrow A. Do not cover holes with threaded features.
- If there is no bedliner fitted, use the remaining tape to cover the 6 holes located on the underside face, indicated by arrow B.
- If there is a liner installed, silicone will need to be applied to the plastic fasteners that hold the front wall in position, indicated by arrow C.

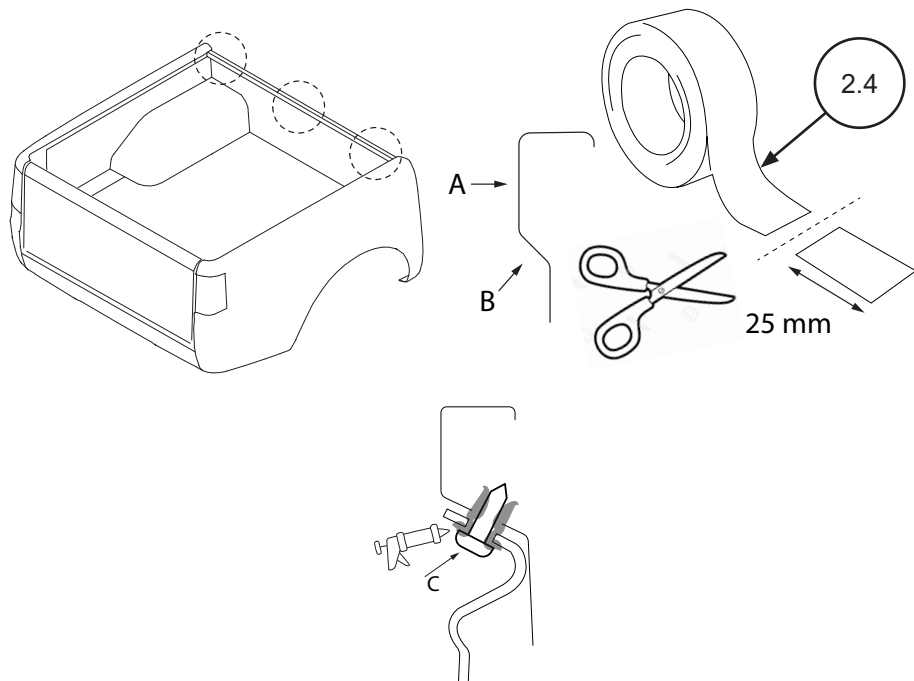



# FORD RANGER 22+ FITTING INSTRUCTION

READ INSTRUCTIONS CAREFULLY BEFORE COMMENCING THIS ACTIVITY.

## Step 4

- Cut item 2.5 into 2 80mm strips.
- Locate the cavities at the front corners, underneath the plastic rail cap.
- Push the foam seal into the cavity and repeat for the opposite side.
- Gently lift the inside front corner of the plastic rail cap.
- Fill the internal void with a generous amount of silicone, refer detail A.
- Let the rail fall back to its natural resting point, fill any areas between the vehicle metal work and plastic rail cap with silicone, refer detail B.
- Install the drip seal mounting channel, item 2.0
- Fill the areas between item 2.0 and the vehicle side rails with silicone.

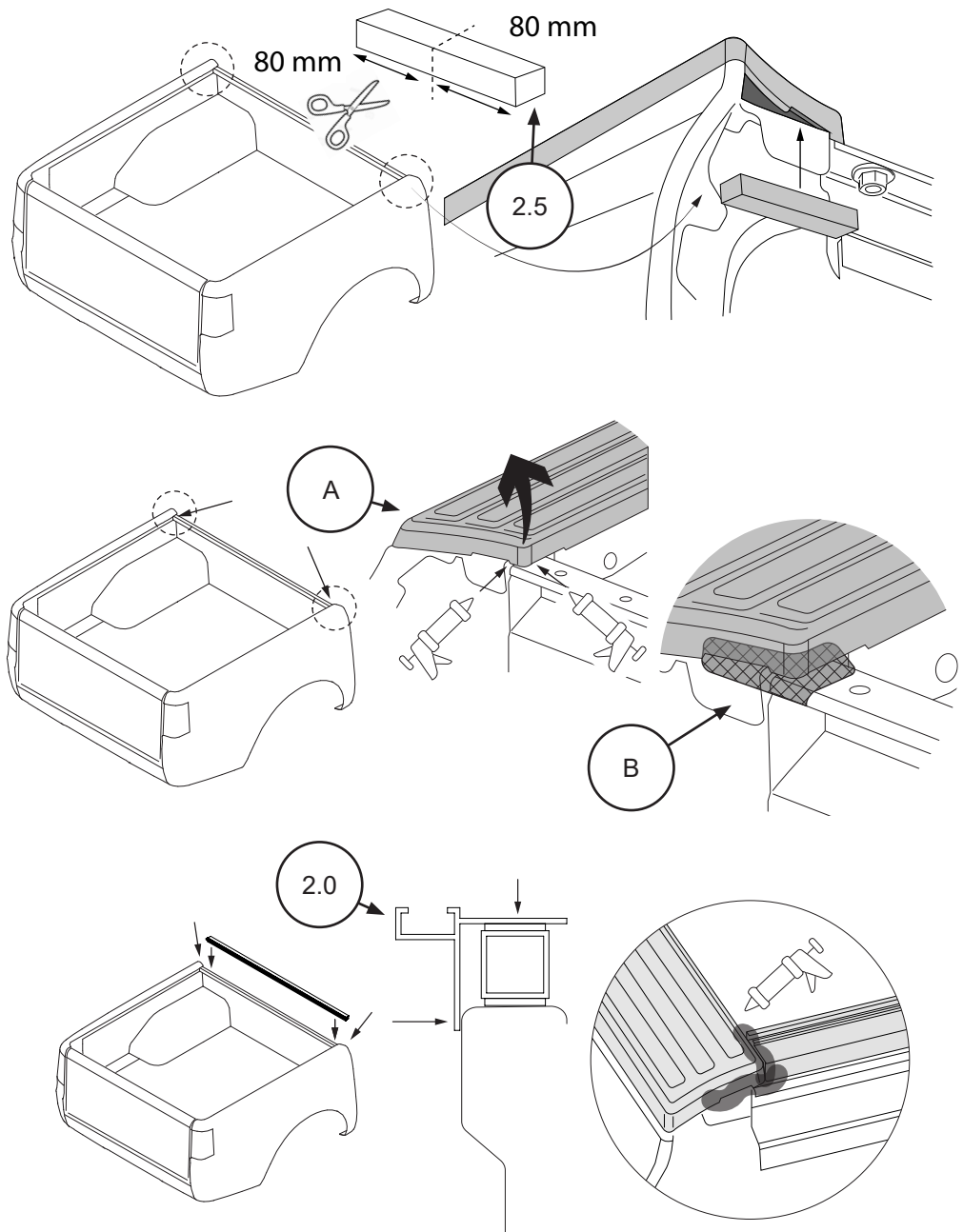

# FORD RANGER 22+ FITTING INSTRUCTION

READ INSTRUCTIONS CAREFULLY BEFORE COMMENCING THIS ACTIVITY.

## Step 5

- Locate the holes beneath the rails, in the front corners of the deck.
- With the recessed tab of the foam block facing downward, push the foam block up under the rail to fill the void. Ensure the recessed tab is hanging down over the sheet metal so that the block does not fall into the cavity.
- Repeat for the opposite side.

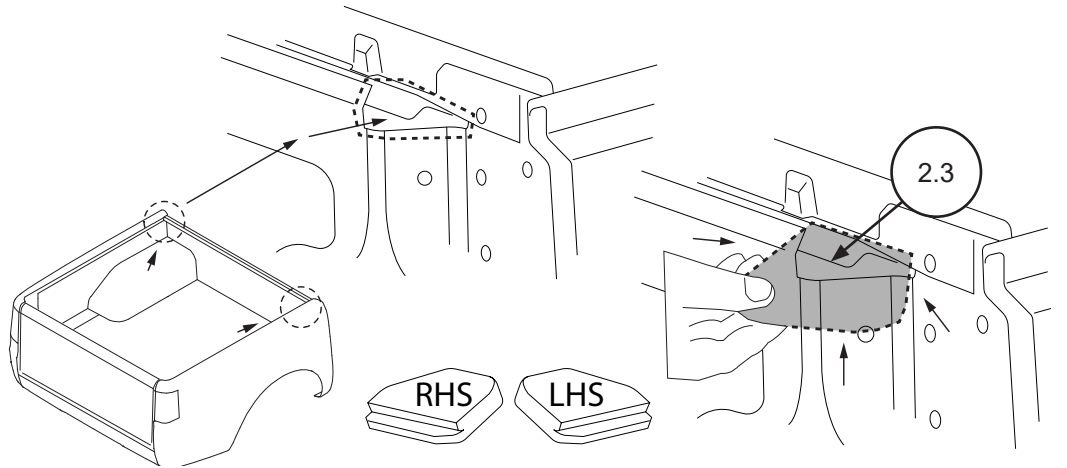

Note: if CMS rail is installed, remove to aid in installation.

## Step 6

- Using non-acetic silicone, seal around the foam blocks filling any holes or voids.
- Inspect the front corners of the vehicle deck and fill any holes or voids.
- Clean up excess silicone.

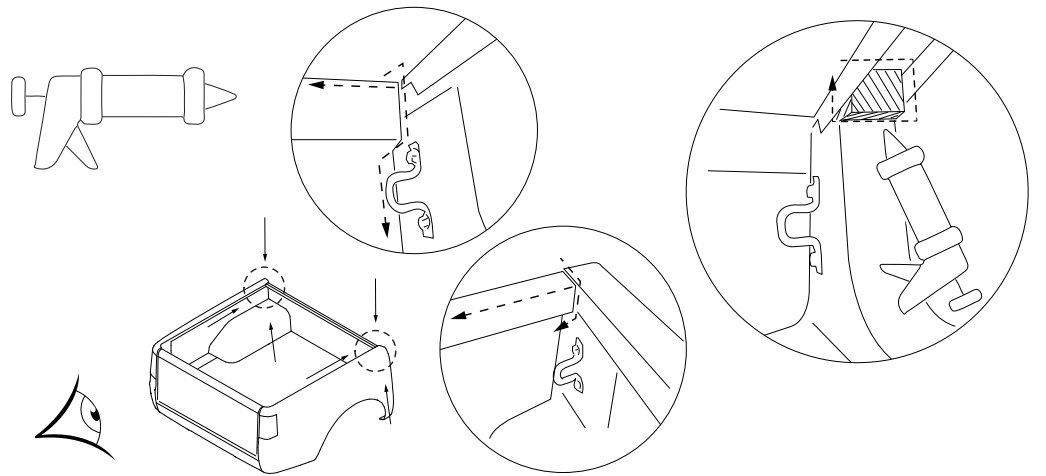

## Step 7 (OPTIONAL)

- Locate the 6 access caps on the tops of the rail caps.
- Apply a bead of silicone around the perimeter of the cap.
- Clean up any excess silicone.

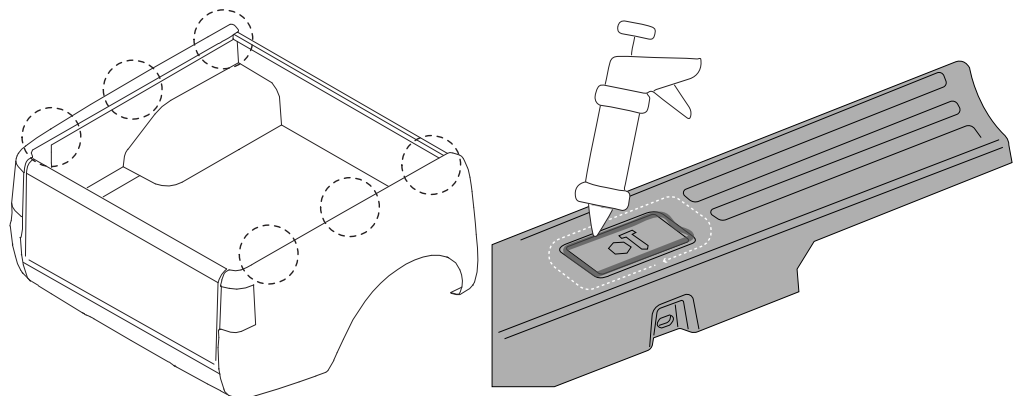

# FORD RANGER 22+ FITTING INSTRUCTION

**READ INSTRUCTIONS CAREFULLY BEFORE COMMENCING THIS ACTIVITY.**

## READ BEFORE PROCEEDING

1. Recommend installing central locking kit before proceeding, refer 10057994 GRP HL FOR RAN 22+ CNTRL LKNG
2. If installing a tub liner, ensure it is installed before proceeding.

### Step 8

- Remove 8 X scrivenets from rail caps.

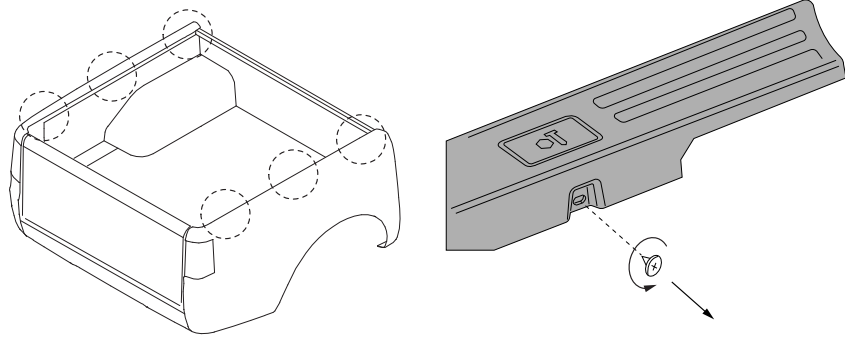

**Note:** If CMS mount rails are not being installed skip to Step 11.

### Step 9

- Ensure the left hand side & right hand side factory mounting brackets are installed in the front corners.
- Use the factory supplied fasteners.
- Install item 3.2 using item 3.10, 3.11 & 3.12.
- Torque M8 fasteners to 8Nm
- Torque M6 fasteners to 6Nm.

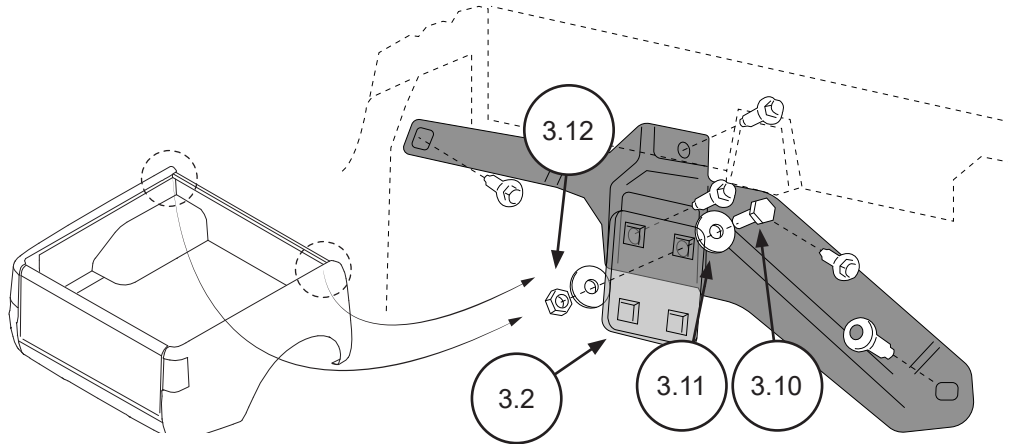

# FORD RANGER 22+ FITTING INSTRUCTION

READ INSTRUCTIONS CAREFULLY BEFORE COMMENCING THIS ACTIVITY.

## Step 10

- Install the left hand side & right hand side central mounting brackets.
- Install item 3.3 & 3.4 using the factory supplied hardware. Position item 3.4 between the plastic rail cap and vehicle tub.
- Orientate item 3.4 with the slot toward the front of the vehicle.
- Torque all fasteners to 6Nm.

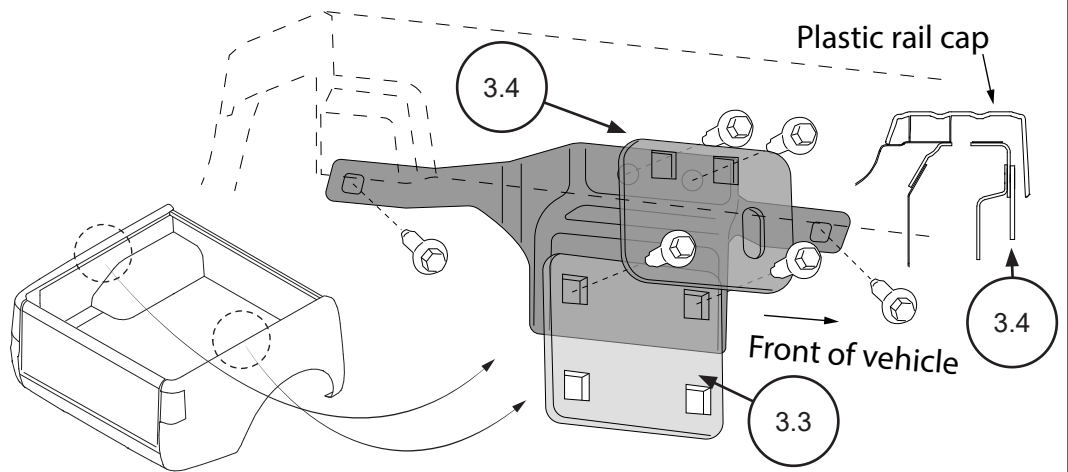

## Step 11

- Do not reinstall the rear factory brackets.
- Retain the M8 screws and nuts.
- Discard the rear factory brackets, M6 screws & M6 nuts.

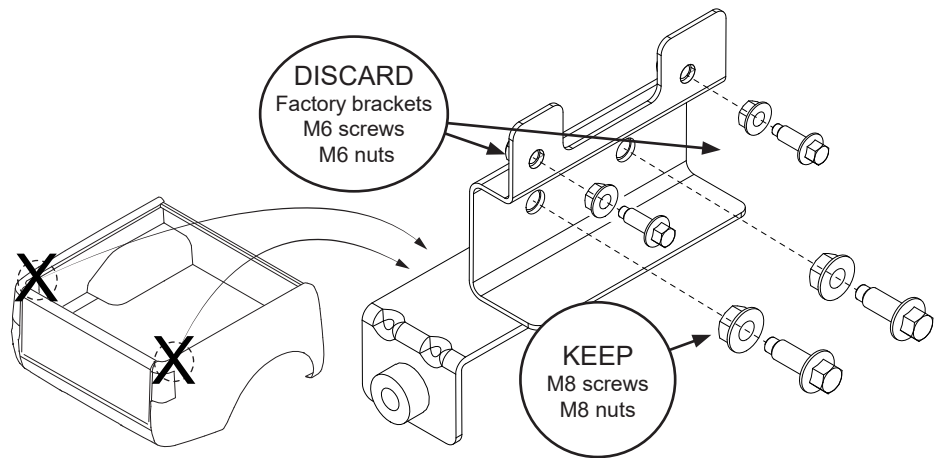

## Step 12

- Install item 3.5 (LHS) and 3.6 (RHS) using the factory hardware saved in step 11 and items 3.9, 3.13 & 3.16
- Ensure that items 3.5 & 3.6 sit inside of the tub sheet metal.
- Torque all fasteners to 8Nm.

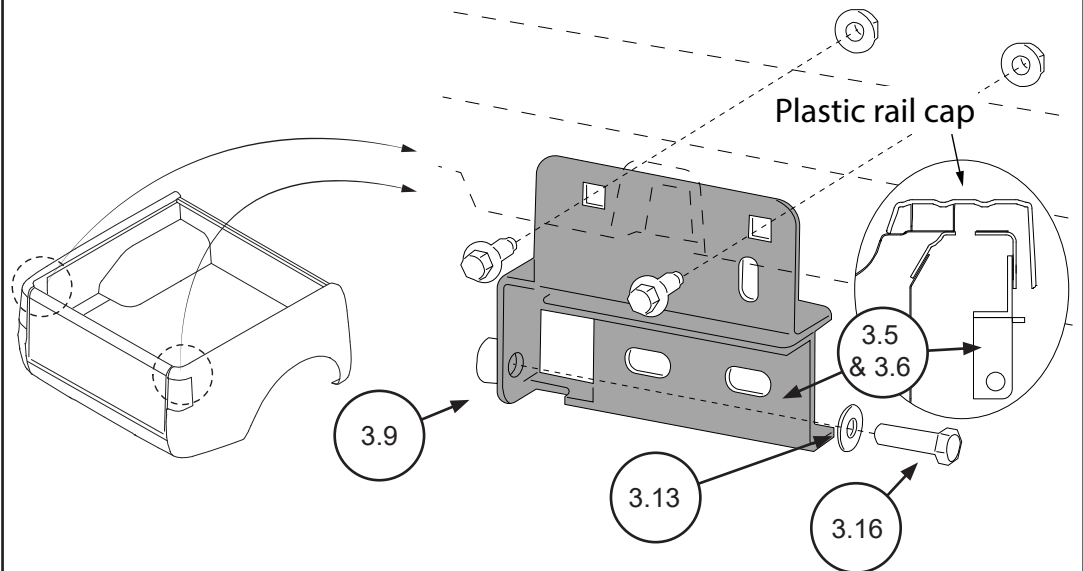

# FORD RANGER 22+ FITTING INSTRUCTION

READ INSTRUCTIONS CAREFULLY BEFORE COMMENCING THIS ACTIVITY.

## Step 13

- Install items 3.0 & 3.1 using items 3.13, 3.15 & 3.17.
- Torque to 8Nm.

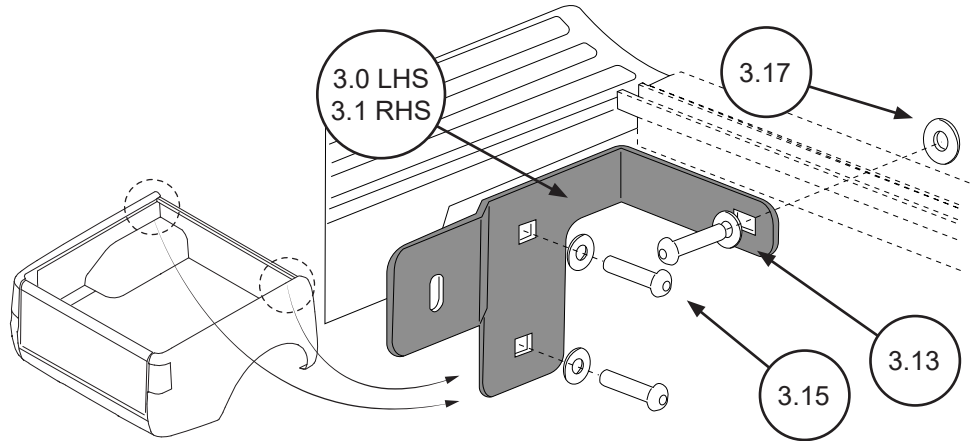

**Note:** If CMS mount rails are being installed skip Step 14. Item already installed in Step 10.

## Step 14

- Install item 3.4 using items 3.10, 3.11 and 3.12.
- Position item 3.4 between the plastic railcap and vehicle tub.
- Torque items to 6Nm
- Reinstall factory scrivers removed in step 8.

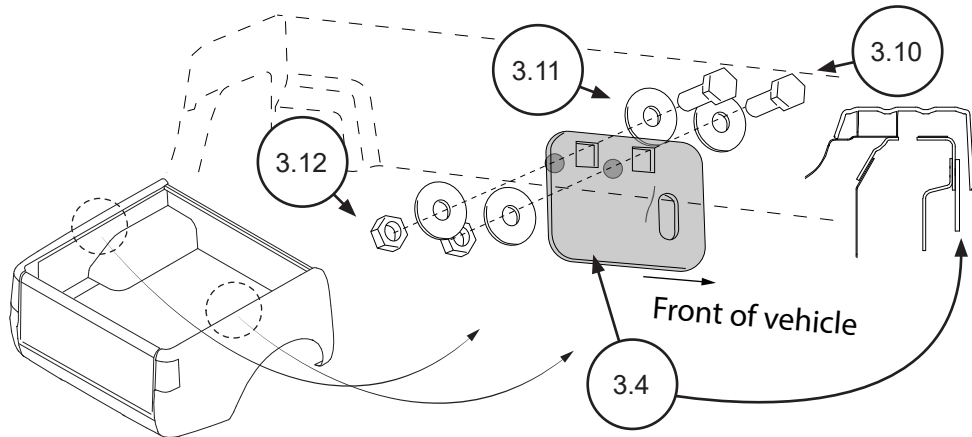

# FORD RANGER 22+ FITTING INSTRUCTION

READ INSTRUCTIONS CAREFULLY BEFORE COMMENCING THIS ACTIVITY.

## Step 15

- Assess sub assemblies 5.0 & 5.1, ensure item 5.2 is 85mm from the front end of the rail.

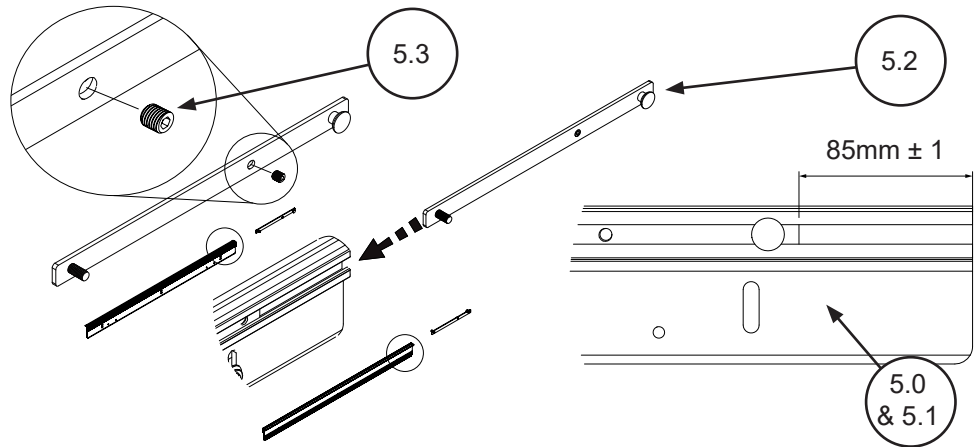

## Step 16

- Loosely attach VCRs 5.0 & 5.1 to vehicle using items 3.7, 3.8, 3.13, 3.14, & 3.15.
- Make sure VCRs are in the correct orientation, item 5.2 located at the front of the vehicle.

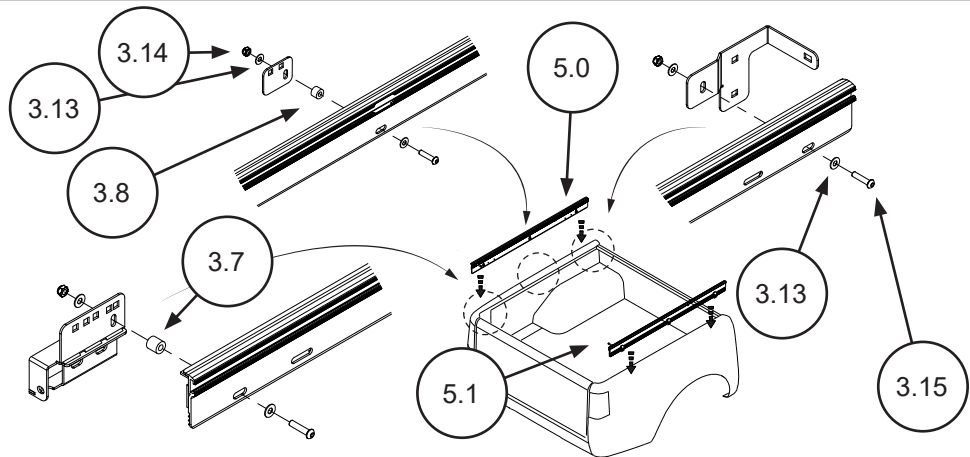

## Step 17

- Position item 5.0 & 5.1 55mm from the inside face of the front header board.
- Apply downward pressure to ensure the foam seal is contacting the top of the vehicle rail.
- Tighten item 3.15 to 8Nm.

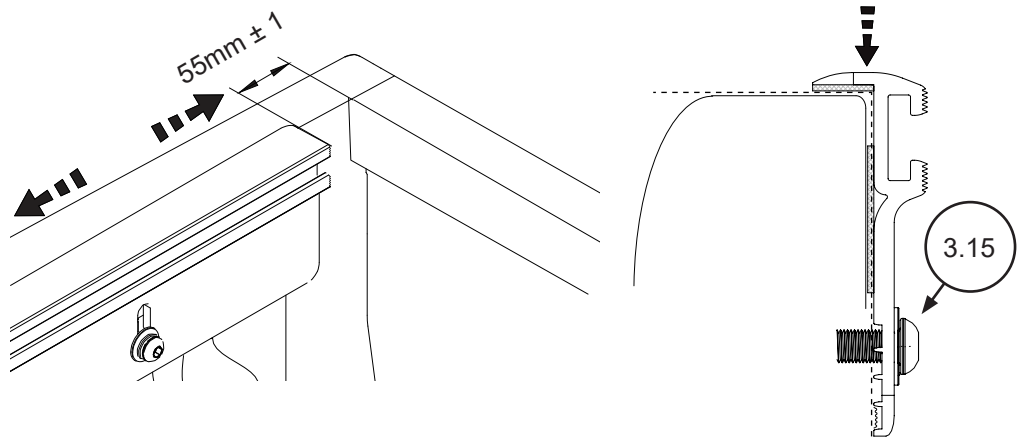

# FORD RANGER 22+ FITTING INSTRUCTION

READ INSTRUCTIONS CAREFULLY BEFORE COMMENCING THIS ACTIVITY.

## Step 18

- Carefully measure the distance between VCR 5.0 & 5.1 and the front edge of the Sealing Channel.
- Cut D-Seal, item 7.5 into two identical portions according to dimension X.

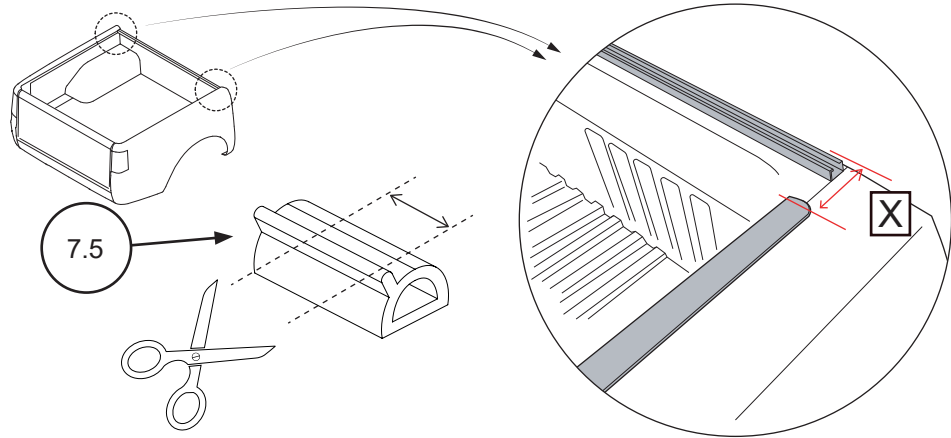

## Step 19

- Clean & prime the vehicle rail using remaining primer from Sealing Kit.
- Ensure the D-Seal, item 7.5 is orientated with the rib facing into the vehicle deck.
- Align the edge of the D-seal, item 7.5 with the inside face of the vehicle rail.
- Push the seal hard up against the Sealing Channel & VCR and ensure there are no gaps between the parts.

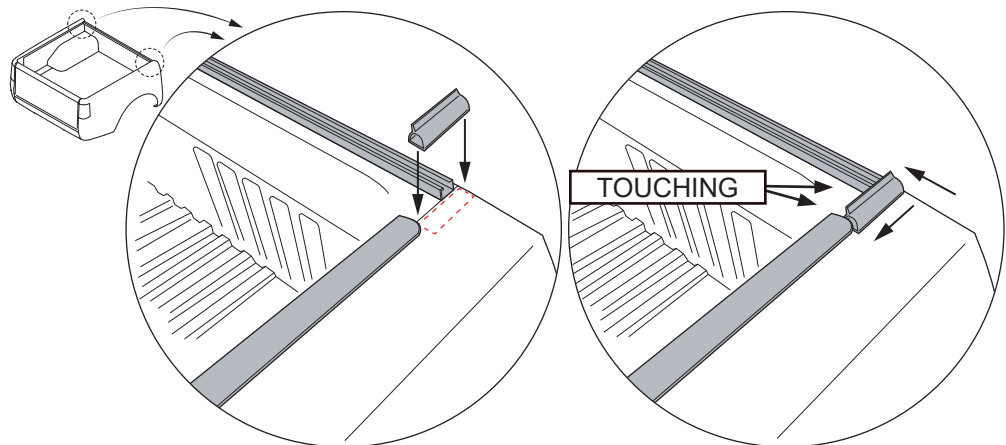

## Step 20

- Fill internal edges between D-seal and drip rail mounting rail with silicone.
- Clean excess silicone with a cloth.

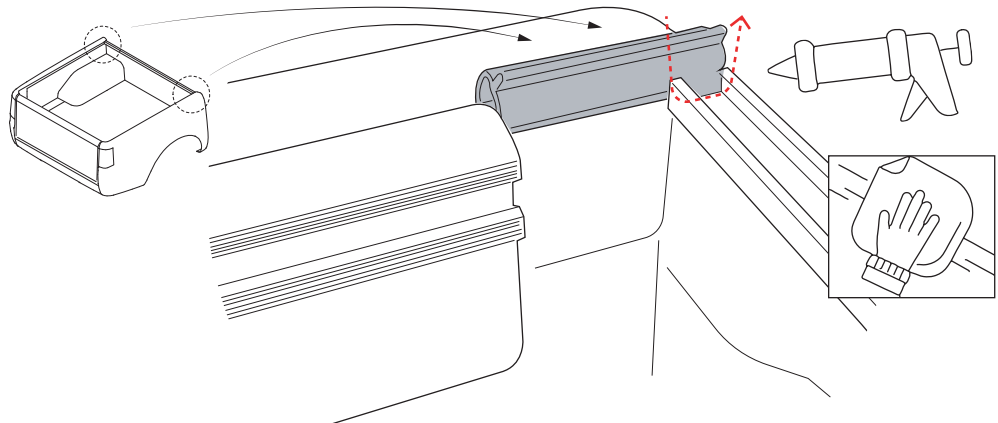



# FORD RANGER 22+ FITTING INSTRUCTION

READ INSTRUCTIONS CAREFULLY BEFORE COMMENCING THIS ACTIVITY.

## Step 21

- Run a bead of silicone approximately 150mm along edge of VCR and into the join between the D-seal.
- Using a wet finger finish the bead neatly.
- Remove excess silicone using a cloth.
- Locate the 4 horizontal rib details.
- Fill the small void with silicone.
- Clean and remove any excess silicone with a cloth.

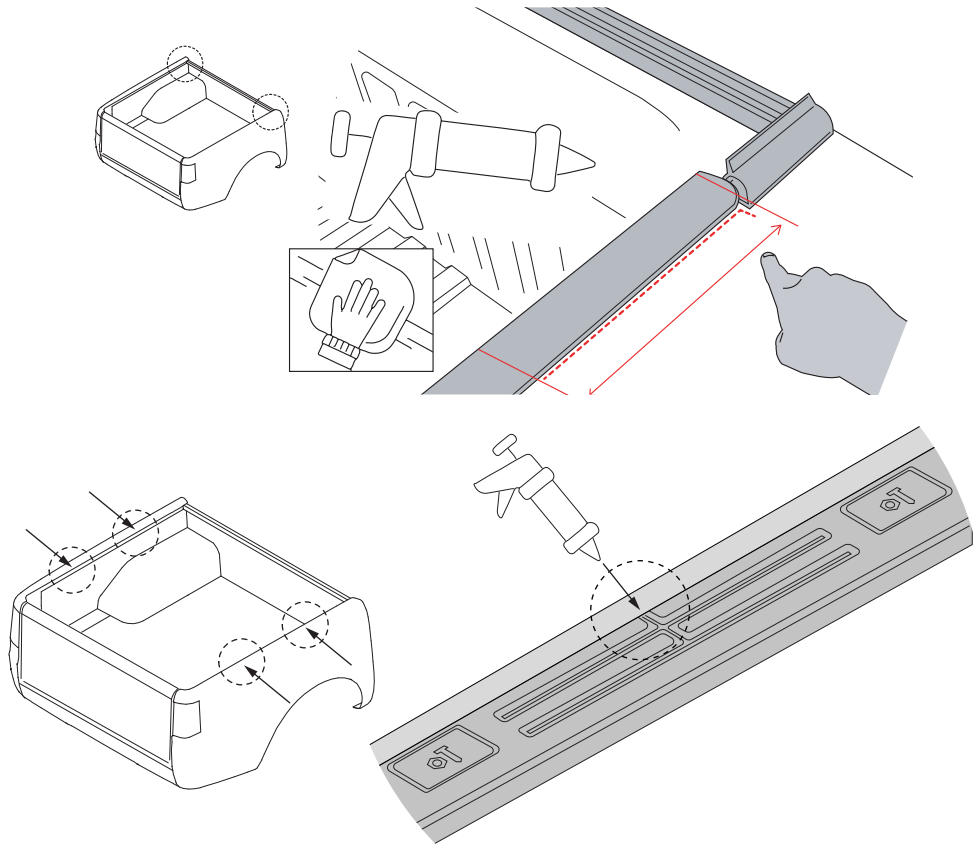

**! If installing a Sport Bar ensure all installation steps are complete before proceeding to next step !**

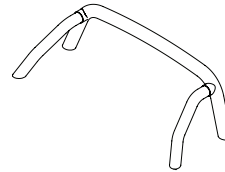

## Step 22

- Install item 2.0 onto items 6.0 & 6.1.

HardLid is supplied with 400N Gas Struts which are suitable for an unloaded lid. We recommend a maximum loading of 25 kgs when opening the lid. If you require your lid to remain open whilst loaded, you will need to purchase a Heavy Load Strut Upgrade kit which is available through your local service centre.

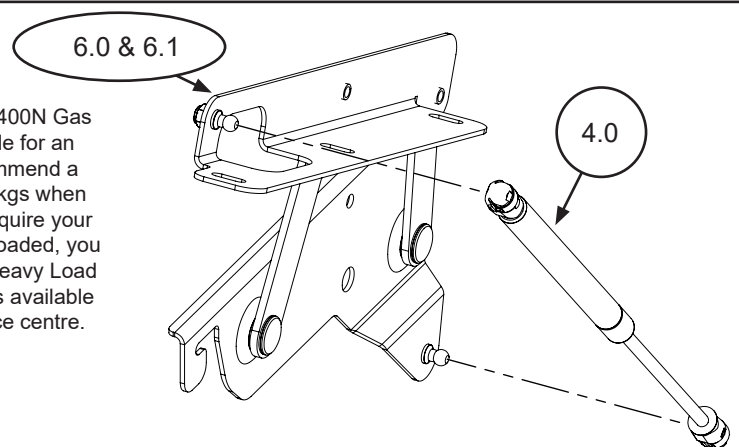



# FORD RANGER 22+ FITTING INSTRUCTION

READ INSTRUCTIONS CAREFULLY BEFORE COMMENCING THIS ACTIVITY.

## Step 23

- Flip the lid over and attach the LHS & RHS (6.0 & 6.1) hinges, using items 7.0 & 7.1
- Ensure the inside edge of the hinge is offset from the inside of the frame by 7mm.
- Torque item 7.0 to **8Nm**.

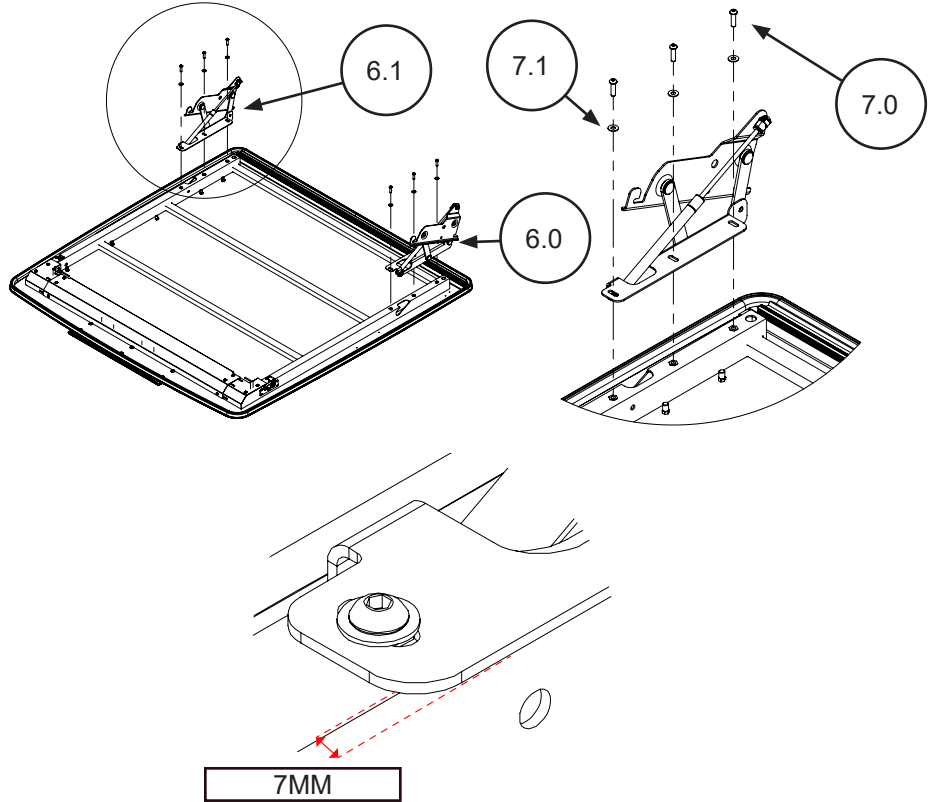

## Step 24

- Install the assembled lid onto the vehicle connector rails.
- 2 person lift required.
- Locate the hinges as per instruction.

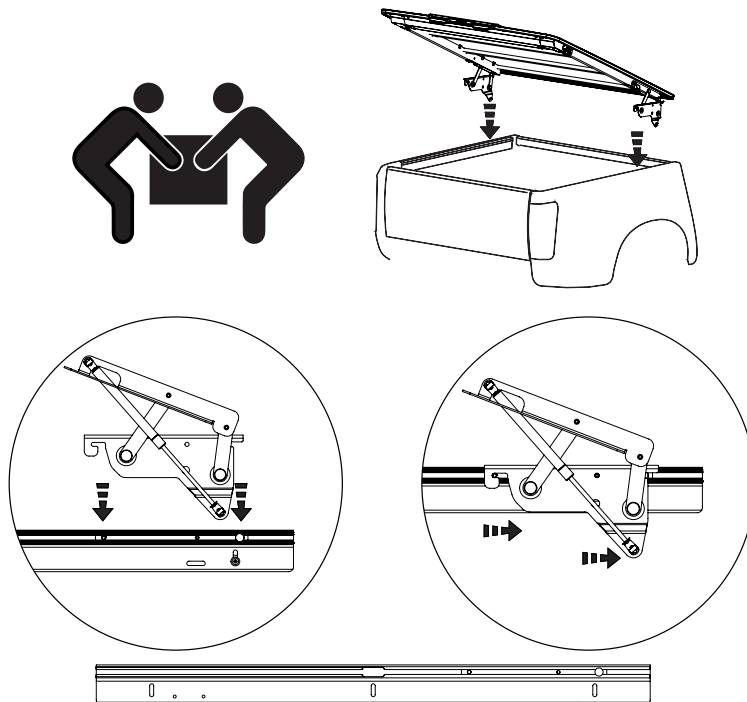

# FORD RANGER 22+ FITTING INSTRUCTION

READ INSTRUCTIONS CAREFULLY BEFORE COMMENCING THIS ACTIVITY.

## Step 25

If the HardLid is exposed to high vibration situations i.e. extended periods of off road driving or applying loads on top of lid, it is recommended that the high vibration packers are installed.

- Tilt the bottom of hinge inward and slide the hinge packer (7.3) up and in behind the hinge. Locate it using the 16mm pilot hole.
- Fasten into position using item (7.2, 7.4 & 7.6). Torque item 7.2 & 7.6 to **8Nm**.
- Repeat for opposite side.

If parts are not installed ensure they are stored with the user manual.

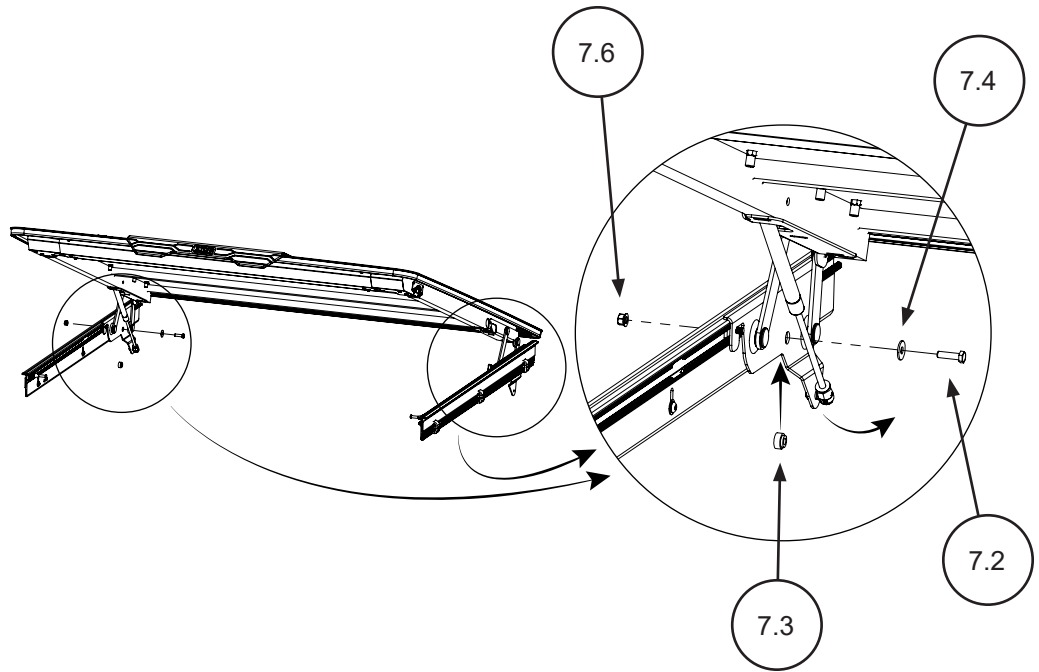

## Step 26

- Install washer (5.6) and thumbscrew (5.4).

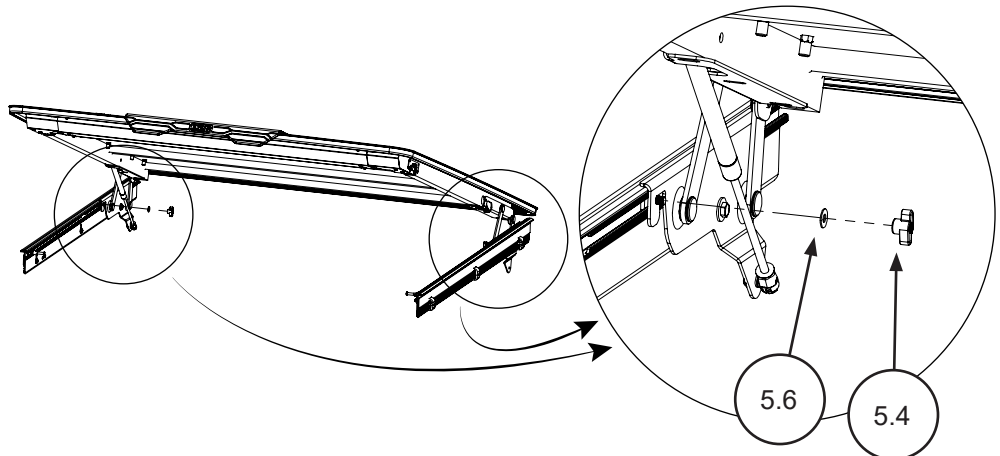

# FORD RANGER 22+ FITTING INSTRUCTION

READ INSTRUCTIONS CAREFULLY BEFORE COMMENCING THIS ACTIVITY.

## Step 27

- Open the vehicle tailgate.
- Close the lid and align the latching pins (5.7) with the latches.
- Close the vehicle tailgate and close the lid again. Check to see that the weather seal is evenly contacting the vehicle surfaces around the perimeter of the vehicle tub.
- If necessary adjust the latch position using the adjustment screw.

Note: ensure the latch fasteners are not tightened.

- Aim for 15-18mm gap between vehicle surfaces and lid.
- Once latch position is confirmed, tighten latch fasteners to **6NM**.

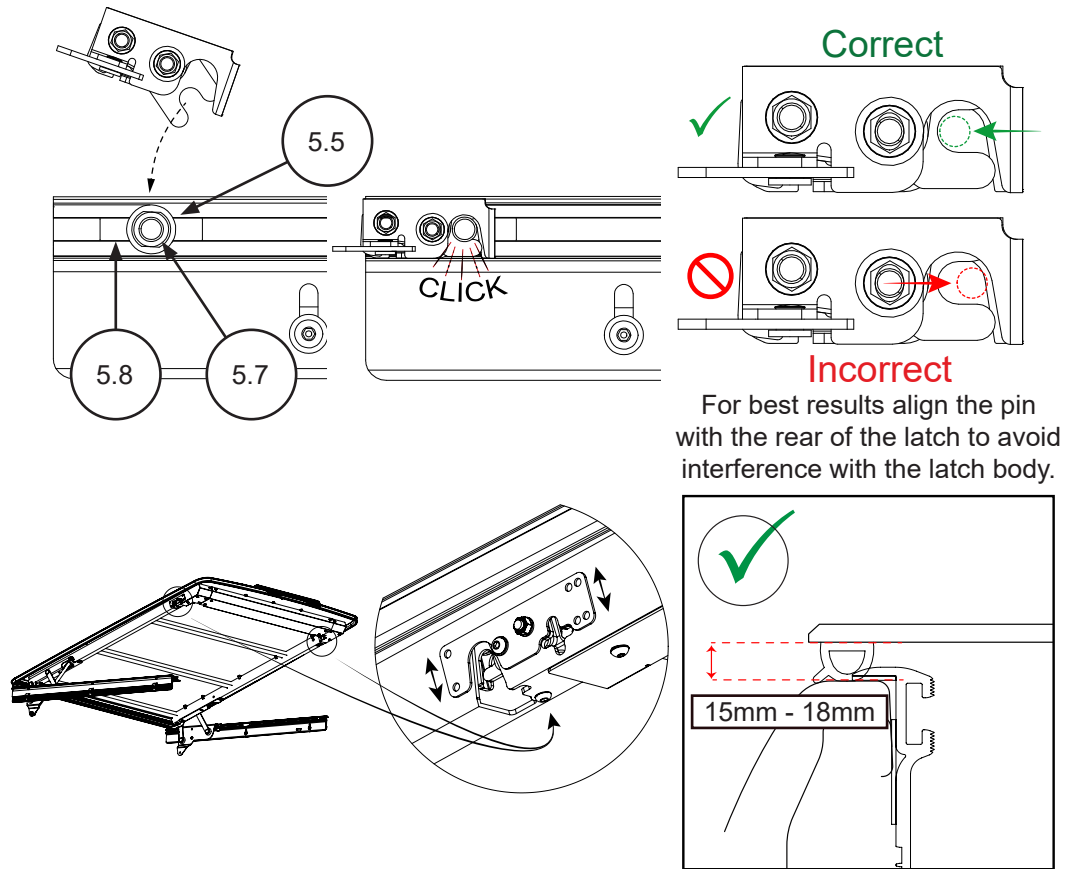

## Step 28

- Once latch height has been set, drill two opposing holes into the lid frame.
- Rivet the latch fastening plate into position using 2 X rivets (7.7) per side.

Note: additional holes have been supplied in case latch needs further adjustment. Do not drill where there is no pilot hole supplied.

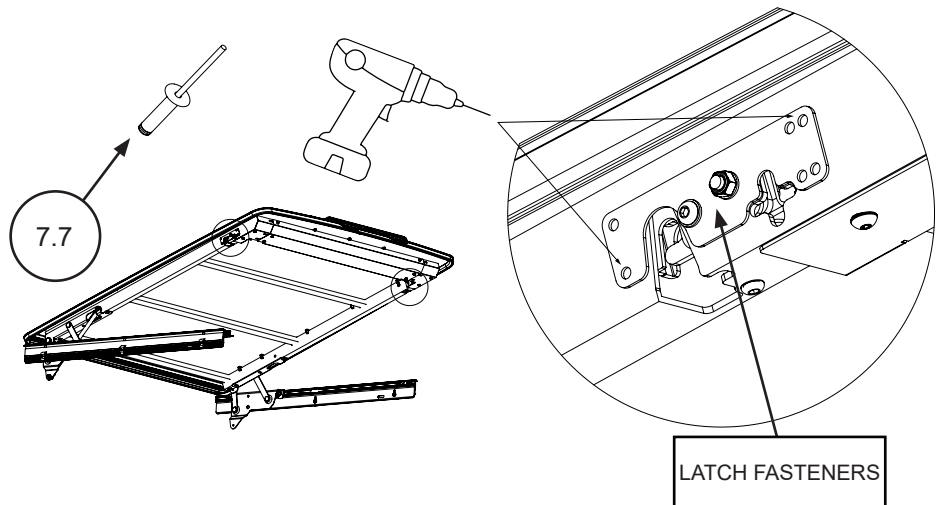

# FORD RANGER 22+ FITTING INSTRUCTION

READ INSTRUCTIONS CAREFULLY BEFORE COMMENCING THIS ACTIVITY.

## Step 29

- Press rubber drip rail into drip rail channel.
- Ensure drip rail is securely locked into channel along full length.

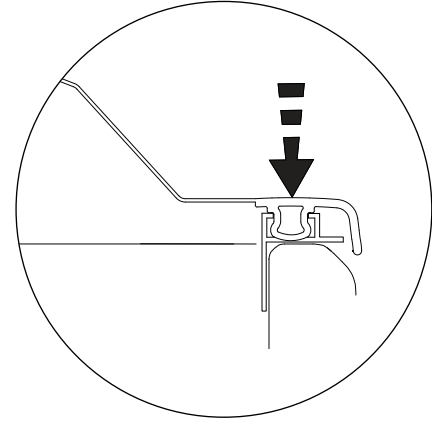
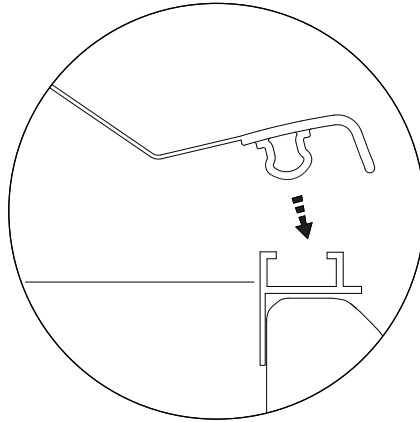

# FORD RANGER 22+ FITTING INSTRUCTION

READ INSTRUCTIONS CAREFULLY BEFORE COMMENCING THIS ACTIVITY.

## Adjustment 1

- Check if the Hinges collide with vehicle connector rails.
- Adjust the hinge locations relative to the lid by loosening screws.
- Re-torque to **8Nm** once complete.

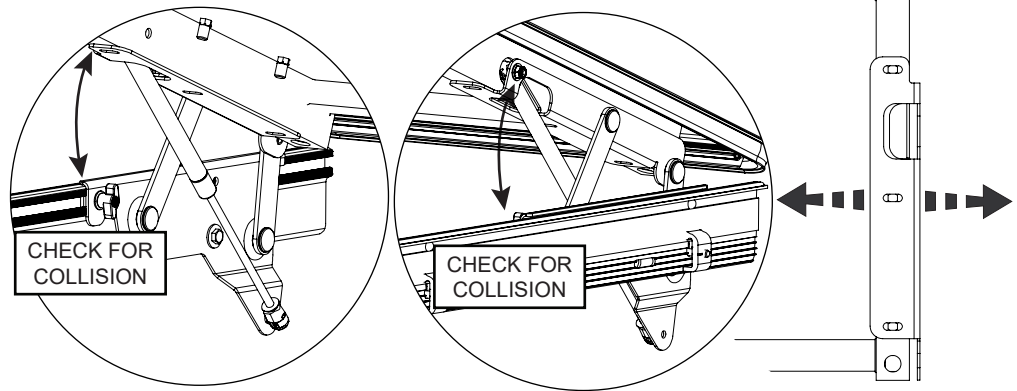

## Adjustment 2

- Check the alignment between lid and vehicle.
- If the lid is twisted the hinges can be shifted individually, forwards or backwards to fine tune the position of the lid.
- If the lid is sitting too far forward or too far rearward the hinges can be moved together.
- Loosen hinge fastening hardware.
- Wind the grub screw outward so that it sits flush with the hinge surface. This will allow you to adjust all components simultaneously.
- Shift the hinges in small increments and re-check offsets until satisfied.
- Once satisfied with position, tighten all fastening hardware.

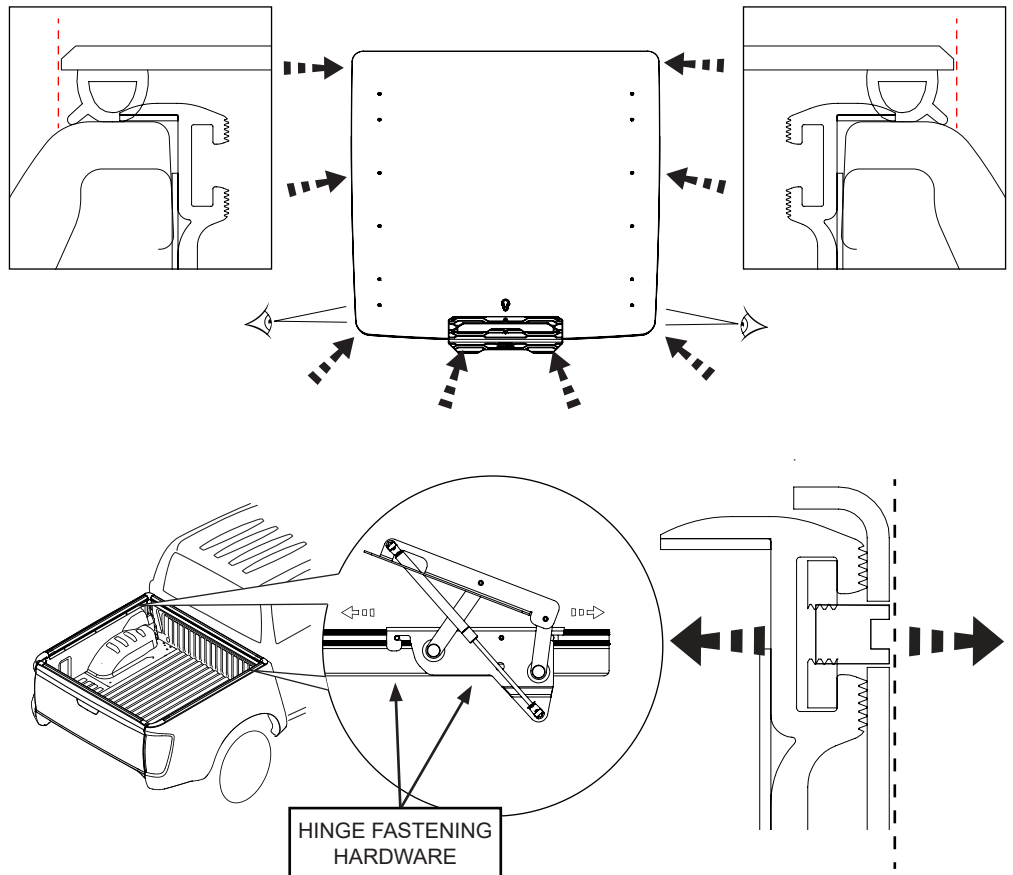

# FORD RANGER 22+ FITTING INSTRUCTION

READ INSTRUCTIONS CAREFULLY BEFORE COMMENCING THIS ACTIVITY.

## Adjustment 4

- If latching sensitivity requires adjusting, cable tension can be increased or decreased.
- Loosen the lock nut and rotate the barrel adjuster anti-clockwise to increase cable tension or clock-wise to decrease cable tension.
- Ensure the lock nut is securely fastened.
- If there is insufficient adjustment at sides, see next step.

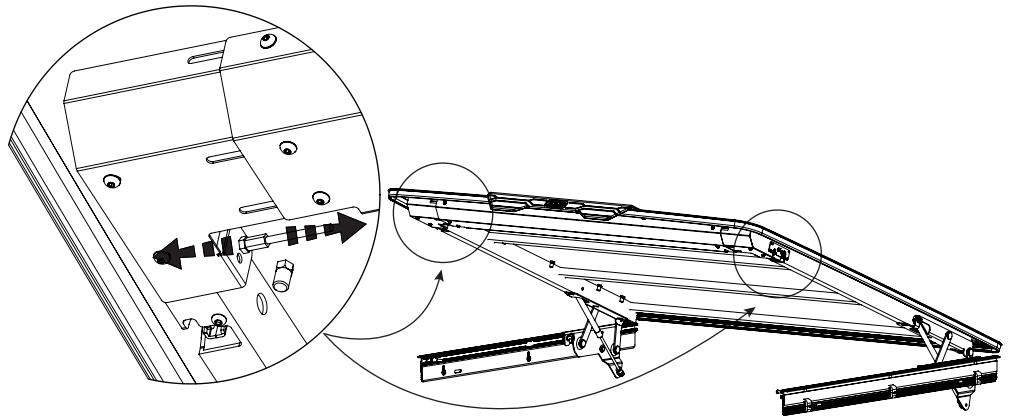

## Adjustment 5

- Remove the service cover.
- Loosen the lock nut and rotate the barrel adjuster anti-clockwise to increase cable tension or clock-wise to decrease cable tension.
- Adjust the cable tension so that the latches operate simultaneously.
- Ensure the lock nut is securely fastened.
- Re-install the service cover when finished.

